



economical



clean air approved



leading design

# Corina Wood Pellet Fire Owners & Installation Manual

PLEASE READ THIS ENTIRE MANUAL BEFORE INSTALLATION, AND USE OF THIS WOOD PELLET FIRE.  
FAILURE TO FOLLOW THESE INSTRUCTIONS COULD RESULT IN PROPERTY DAMAGE, BODILY INJURY,  
OR EVEN DEATH.

Contact your local building or fire official about restrictions and installation requirement in your area.

## **ATTENTION**

*If you are not a registered pellet fire installer, and do not have legitimate access to the necessary passwords to install and program the Corina Wood Pellet Fire, you MUST NOT install or attempt to install this fire.*

*The Corina Wood Pellet Fire requires technical programming and individualised air adjustments to ensure it will operate safely and efficiently, and to avoid possible damage to the fire or home.*

*Installation of the Corina Wood Pellet Fire by a non-registered installer will void the warranty, and may result in your local authority refusing to approve the necessary permits.*

*If you require a registered Pellet Fire Solutions Installer, please contact us directly on [info@pelletfiresolutions.co.nz](mailto:info@pelletfiresolutions.co.nz)*



## Owner's Section - Table of Contents

<b>1.</b>	<b>Introduction.....</b>	<b>5</b>
	<b>1.1 Specifications.....</b>	<b>5</b>
<b>2.</b>	<b>Safety Warnings &amp; Recommendations.....</b>	<b>6</b>
	<b>2.1 Installation.....</b>	<b>6</b>
	<b>2.2 Deciding where to locate your wood pellet burning fire.....</b>	<b>7</b>
	<b>2.3 Ash.....</b>	<b>7</b>
	<b>2.4 Clinkering.....</b>	<b>7</b>
	<b>2.5 Filling Fuel Hopper.....</b>	<b>7</b>
	<b>2.6 Flammable Liquids.....</b>	<b>8</b>
	<b>2.7 Operating Instructions.....</b>	<b>8</b>
	<b>2.8 Safety Devices.....</b>	<b>8</b>
	<b>2.9 Responsibility.....</b>	<b>8</b>
	<b>2.10 Spare Parts.....</b>	<b>8</b>
<b>3.</b>	<b>What are Wood Pellets?.....</b>	<b>9</b>
<b>4.</b>	<b>The Components of the Stove.....</b>	<b>9</b>
	<b>4.1 Pellet Combustion.....</b>	<b>10</b>
<b>5.</b>	<b>Maintenance and Cleaning.....</b>	<b>11</b>
	<b>5.1 Routine Cleaning.....</b>	<b>11</b>
	<b>5.2 Glass Cleaning.....</b>	<b>11</b>
	<b>5.3 Combustion Chamber Cleaning.....</b>	<b>11</b>
	<b>5.4 Cleaning the Ash Drawer.....</b>	<b>12</b>
	<b>5.5 Cleaning the Pellet Hopper.....</b>	<b>12</b>
	<b>5.6 Servicing.....</b>	<b>12</b>
	<b>5.7 End of Season.....</b>	<b>14</b>
	<b>5.8 Trouble Shooting.....</b>	<b>14</b>

<b>6.</b>	<b>Operating your Pellet Fire.....</b>	<b>15</b>
6.1	Description of Handheld Set.....	15
6.2	Handheld Touch Radio Initialization.....	15
6.3	Description of the Display.....	16
6.4	Time and Date Settings.....	17
6.5	Loading the Auger.....	17
6.6	Setting Operating Temperature and Power.....	18
6.7	Turning the Device on.....	18
6.8	Operating Phases of the Stove.....	18
6.9.1	Alarms .....	25
<b>7.</b>	<b>Maintenance Record.....</b>	<b>27</b>
<b>8.</b>	<b>Warranty Information.....</b>	<b>28</b>
8.1	Warranty Coverage.....	28
8.2	Warranty Period.....	28
8.3	Warranty Exclusions.....	29
<b>9.</b>	<b>Proof of Purchase/Warranty.....</b>	<b>30</b>

# 1. Introduction

This manual is designed for both the technician and the home owner.

Please read this entire manual before installing or operating your Ravelli Corina Insert Wood Pellet Burning Stove. Failure to follow these instructions may result in property damage, bodily injury or even death. Any unauthorized modification of the appliance, or use of replacement parts not recommended by the manufacturer is prohibited. All national and local regulations shall be complied with when installing this appliance. Your local Pellet Fire Solutions dealer will be happy to assist you in obtaining information with regards to your local building codes and installation restrictions.

## 1.1 Specifications

### 1.1.1 Rating label Location

Ravelli Corina Insert The rating label is located on the back of the unit.

\*Note: Consumption will vary with the type of fuel used.

Classification	Testing Standard	Description
Class I IP-20	Efficiency: AS/NZS 5078:2007 Appliance: AS/NZS 4866:2007	Residential Wood Pellet Stove
Voltage 220- 240 Volt	Current: 2.92 —3.18 Amps	Frequency: 50Hz
Max Power Requirement 280 watts	Unit with full hopper: 145kg	Hopper Capacity: 20kg
Mean Flue Gas Temp — High: 165 degrees	Mean Flue Gas Temp- Medium: 135 degrees	Mean Flue Gas Temp- Low: 112 degrees
Fuel Consumption — High: 1.45 kg per hour	Fuel Consumption — Medium: 1.0 kg per hour	Fuel Consumption — Low: 0.6 kg per hour
Heat/Power Output — High: 9.0kw	Heat/Power Output — Medium: 6.0kw	Heat/Power Output — Low: 3.0kw
Average Particular Emissions (dry weight) 0.23 gms per kg	Average Emissions Rate 14mg/MJ	Average Efficiency 84%
Gross Calorific Value of pellets (dry weight)  20.1MJ/kg	Fuel Type: Wood pellets —6mm dia, - complying with draft standard AS/NZS 4014.6 2008	

**IMPORTANT:** The above values were found during testing and may vary with the fuel type, climate and installation style.

## 2. Safety Warnings & Recommendations

Pellet quality is important, please read the following:

Your pellet heater has been designed to burn ¼" (6mm) diameter wood pellets, manufactured to the AS/NZS 4014.6 only.

DO NOT use this appliance as an incinerator.

DO NOT use unsuitable and non recommended fuels, including liquid fuels, as this will void any warranties stated in the manual.

The performance of your pellet stove is greatly affected by the type and quality of wood pellets being burned. As the heat output of various quality wood pellets differs, so will the performance and heat output of the pellet stove.

Caution: It is important to select and use only pellets that are dry and free of dirt, or any impurities such as high salt content. Wood pellets manufactured to the AS/NZS 4014.6 standard are recommended. Dirty fuel will adversely affect the operation and performance of the unit and will void the warranty. The Pellet Fuel Industries (PFI) has established standards for wood pellet manufacturers. We recommend the use of pellets that meet or exceed these standards. Ask your dealer for a recommended pellet type.

### 2.1 Installation

The stove must be installed and tested by specialised personnel approved by Pellet Fire Solutions. Please read this manual before installing or operating the stove. If you require further information, please contact your Pellet Fire Solutions dealer. Installation must be performed by authorized personnel, who must give the purchaser a declaration of conformity of the appliance, and who will assume all responsibility for the final installation and consequent correct functioning of the product installed. It is also necessary to take into consideration all the laws and national, regional, provincial and local regulations present in the country in which the appliance has been installed. In the event of failure to respect these precautions, Pellet Fire Solutions declines all responsibility.

#### **IMPORTANT:**

- The place of installation of the stove must comply with local & national regulations. The stove must be fuelled only with quality pellets manufactured to standard AS/NZS4014.6. The stove cannot operate with traditional wood.
- The stove must not be used as an incinerator.
- Before connecting the stove electrically, the connection of the exhaust spigot must be completed (specifically for pellet stoves, not made from aluminum) with the flue. (All flue joins must be sealed with maniseal exhaust cement).
- The protection grill inside the pellet tank must never be removed.
- There must be sufficient circulation of air in the room where the stove is installed. Never open the door of the stove whilst it is functioning.
- When the stove is operating, the surfaces, the glass, the handle and the pipes become overheated: during functioning, these parts must only be touched with the adequate protection.
- Do not light the stove without having first performed the daily inspection as described in the MAINTENANCE & CLEANING chapter of this manual (see page 11).
- Scrupulously follow the maintenance program.
- Do not turn the stove off by disconnecting the electricity mains supply (use the remote control).

- Do not clean the stove until the structure and the ashes have cooled down completely. Carry out all operations with maximum safety.

Corina should be installed in a centrally located position within the home. This will assist the appliance to perform to the level required. As the Corina heats space by convecting air through the top of the unit, the heater should face the majority of the area to be heated.

Corina requires a power source to function. This is standard mains feed 240v plug - if this is unavailable in close proximity, a grounded extension lead may be used.

Corina is to be installed on a non-combustible surface, which must have a forward projection of a minimum of 150mm from the glass door.

Please check all clearances to combustibles as listed on page 35 of this Owner's/Technical manual.

In accordance with the requirements of AS/NZS 2918:2018, Corina must be secured by seismic restraint.

## **2.2 Deciding where to locate your wood pellet burning stove**

1. Do not install the pellet stove in a bedroom or room where people sleep.
2. Locate the pellet stove in a large and open room that is centrally located in the house. This will optimise heat circulation.
3. Check clearances to combustibles (refer page 35).

## **2.3 Ash**

The ash content of the fuel and operation of your stove will directly determine the frequency of cleaning. The use of high ash fuels may result in the stove needing to be cleaned daily. A low ash fuel may allow longer intervals between cleaning.

## **2.4 Clinkering**

Clinkers are silica (sand) or other impurities in the fuel that will form a hard mass during the burning process. This hard mass will block the air flow through the burn pot liner, and affect the performance of the stove. Any fuel, even approved types, may clinker. Check the burn pot liner daily to ensure that the holes are not blocked with clinkers. Refer to the Routine Cleaning and Maintenance section.

## **2.5 Filling Fuel Hopper**

Check hopper for foreign objects, then empty the bag of pellets into the hopper. **DO NOT OVER FILL**, as miscellaneous pellets could smoke if left to rest on an operating stove.

Store pellets at least one metre (1m) away from the pellet stove.

Warning: parts of the appliance, especially the external surfaces, will be hot to touch when in operation so use due care.

## **2.6 Flammable Liquids**

Never use gasoline, gasoline —type lantern fuel, kerosene, charcoal lighter fluid or similar liquids to start or “freshen” up a fire in the stove. Keep all such liquids well away from the stove while it is use.

## **2.7 Operating Instructions**

The stove is completely automated and will self-regulate the ignition phase, five levels of power and the switching off phase, guaranteeing safe functioning. The burn pot used for combustion allows most of the ashes produced by the combustion of the pellets to fall into the collection drawer. However, it is recommended that you check the burn pot every day, as not all pellets have high standards of quality, and could leave residue that is difficult to remove. The glass has special air circulation for self-cleaning, however, a slight greyish film cannot be avoided after a few hours of functioning. Pellets with a diameter of 6mm, manufactured to the AS/NZ4014.6 or higher must be used with the stove.

## **2.8 Safety Devices**

The stove is fitted with a sophisticated safety systems so that, in the case of breakage of one of the individual parts, or defects in the flue, no damage will be caused to the stove and the room in which it is installed. In any case, when a problem arises, the pellets stop falling immediately and the switch off phase is activated. The corresponding alarm will be shown on the display. The details can be seen in the chapter on the alarms (see page 25 and 26).

## **2.9 Responsibility**

Pellet Fire Solutions declines all responsibility, both civil and criminal, with the delivery of this manual, for any accidents deriving from partial or total failure, to observe the instructions it contains.

Pellet Fire Solutions declines all responsibility deriving from the improper use of the stove, from its incorrect use by the user, by unauthorised modifications and/or repairs, or from the use of spare parts which are not original. The manufacturer declines all direct, civil or criminal responsibility due to:

- Poor maintenance.
- Failure to observe the instructions in the manual.
- Use not compliant with the safety instructions.
- Installation that is not compliant with the regulations in force in the country.
- Installation by personnel who are not qualified or authorised.
- Modifications and repairs that are not authorized by the manufacturer.
- Use of spare parts that are not original.
- Exceptional events.

## **2.10 Spare Parts**

Use original spare parts only. Do not wait for the components to be worn before replacing them. Replace a worn component before it is completely broken, to prevent any accidents caused by the sudden breakage of components. Perform the periodic maintenance checks as described in the dedicated chapter on “Maintenance and Cleaning” on page 11 .



### 3. What are Wood Pellets?

Wood pellets are made from sawdust and wood shavings. The material used cannot contain any foreign substance such as glue, varnish or synthetic substances. Subjecting it to high pressure, the wood is pressed through a plate with holes, and due to the high pressure, the sawdust is heated activating the natural binders of the wood. Thus, the pellets keep their shape even without the addition of bonding substances. The density of the wood pellet varies according to the type of wood and can be 1.5—twice greater than that of natural wood. The diameter of the cylindrical rods is 6-10 mm and their length can vary between 10 and 50 mm. Their weight is equal to about 650 kg/m. Due to the low content of water (approx 8%) they have a high energy content. The standards AS/NZS4014.6 define the quality of the pellets:



Do not put the bag of pellets on the cast parts during the loading operations.

The pellets must be transported and stored in a dry place. They swell on contact with any moisture and cannot be used. They must always be protected from moisture, both during transport and in storage. Ravelli recommends using a pellet with a diameter of 6 mm for the stove.

### 4. The Components of the Stove

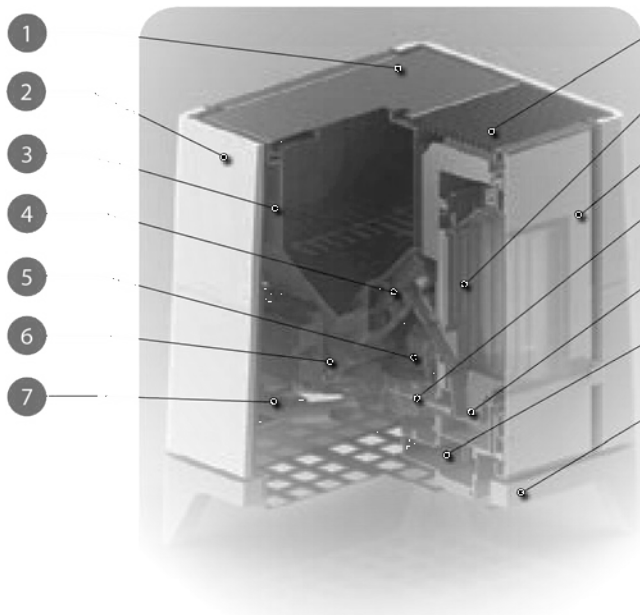

- 1 Pellet hopper
- 2 Pellet hopper
- 3 Pellet hopper
- 4 Pellet hopper
- 5 Pellet hopper
- 6 Pellet hopper
- 7 Pellet hopper
- 8 Pellet hopper
- 9 Pellet hopper
- 10 Pellet hopper
- 11 Pellet hopper
- 12 Pellet hopper
- 13 Pellet hopper
- 14 Pellet hopper
- 15 Pellet hopper

## 4.1 Pellet Combustion

Combustion is simply a chemical reaction between combustible and carburant. The result of this reaction is the heat.

The three elements that are required for combustion are:

- Combustible (pellet)
- Carburant (oxygen available in the air)
- Ignition (electrical resistance for ignition)

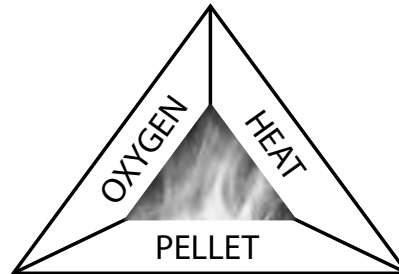

To achieve combustion, the combustible and the carburant must be available in the correct proportions.

The reaction between combustible and carburant is made by an external starter. Ignition can be created by direct contact with a heat source, or by a spark. Incorrect combustion is evident when the flame is too tight, and there are too many incandescent pellets in the firepot.

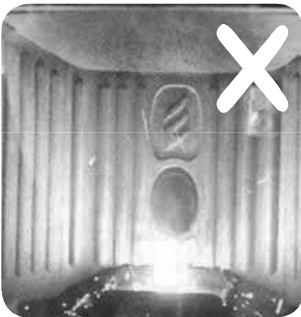

**INCORRECT** combustion - the flame is weak and there are a lot of unburned pellets in the firepot. Check first that the ash pan is properly closed. Then adjust set pellet/air increasing the air percentage (from 0 up to +5). If this doesn't work, try increasing the loading quantity of the pellet (from 0 up to -5) to reach the flame condition shown in picture 3.

If with the adjustments done, the flame is not reaching the condition shown in picture 3, contact After Sales Service.



The combustion is **NOT CORRECT**, the flame is weak and a lot of unburned pellet wood in the firepot. Check first that the ash pan is properly closed. Then adjust set pellet/air increasing the air percentage (from 0 up to +5); in the event this is not enough, increase the loading quantity of the pellet (from 0 up to -5) to reach the flame condition shown in picture 3.

If with the adjustments done, the flame is not reaching the condition shown in picture 3, contact After Sales Service.



The combustion **IS CORRECT**, full flame, yellow/white, and minimum quantity of pellet in the firepot.

The combustion is fine, and no ash.

The picture 3 shows a flame with a stove working at power P5.

## 5. Maintenance and Cleaning



Maintenance of the stove must be performed at least once a year and should be planned in advance with the Technical Assistance Service.



In some conditions, such as turning the stove on and off or inappropriate use, the combustion products can contain small soot particles that build up in the smoke evacuation system. This can reduce the cross-section of the smoke duct and pose a fire risk.

The smoke evacuation system must be inspected and cleaned at least once a year.



The maintenance operations must be carried out when the stove is cold and with the electrical power supply disconnected.

Before completing any maintenance operation, adopt the following precautions:

- Make sure that all stove parts are cold.
- Make sure that the ashes are completely cold.
- Always operate with equipment that is appropriate for maintenance.
- When maintenance is finished, re-install all of the dis-assembled parts before restarting operation.

### **! IMPORTANT**

The quality of the pellet, the stove operating mode and combustion control can affect maintenance activity frequency.

### 5.1 Routine Cleaning

#### **! IMPORTANT**

Perform the cleaning operations so as to guarantee correct stove operation. The table below lists the necessary cleaning operations required for correct stove operation.

PARTS / FREQUENCY	1 DAY	2-3 DAYS	60-90 DAYS
Combustion chamber	•		
Combustion grille	•		
Ash drawer	•		
Glass		•	
Extraction duct			•

### 5.2 Glass Cleaning

With a cold stove, clean the glass with a cloth and glass cleaner.

Note: there are stove glass cleaning products available on the market.

### 5.3 Combustion Chamber Cleaning

To clean the ash drawer, proceed as follows:

step	action
1	The stove requires a simple yet frequent cleaning in order to guarantee suitable yield and regular operation. Vacuum the combustion chamber every day using a bin ash vacuum, making sure that the ashes are completely cold.

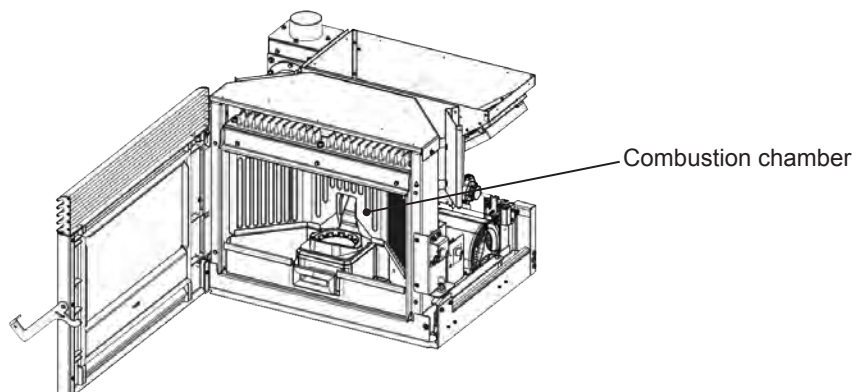

## 5.4 Cleaning the Ash Drawer

The ash drawer must be cleaned every 30 days, (depending on the amount of time the stove is used and what type of pellet is used). To clean the ash drawer, proceed as follows:

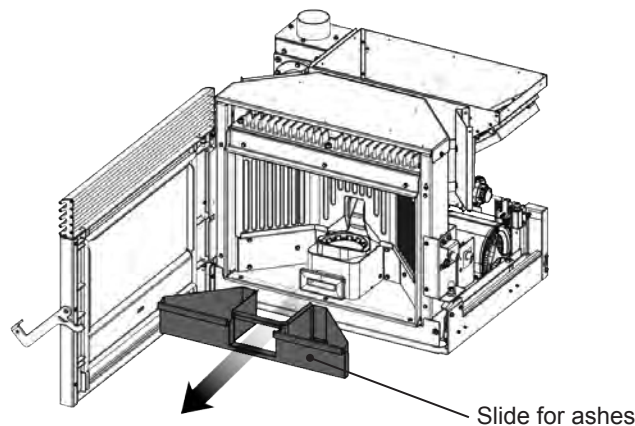

## 5.5 Cleaning the Pellet Hopper

To clean the pellet tank, proceed as follows:

step	action
1	Periodically remove the wood sawdust accumulated on the bottom of the tank, using a vacuum cleaner.

## 5.6 Servicing

### ! IMPORTANT

This operation must be carried out by a Ravelli Assistance Centre. Schedule this type of cleaning with the Ravelli Assistance Centre. The smoke conduit must be cleaned every 3 months.

step	action
1	Open the hatches.
2	Clean the ashes, eventually use a brush or similar and reassemble everything. Note: the hatches are equipped with gaskets, therefore, before reassembling them, make sure that the gaskets are not worn.

**Note:** The operation must be carried out with a cold stove, using an ash-type aspirator.

### Extraordinary maintenance



Extraordinary maintenance activities must be carried out by staff from the Authorised Assistance Centre.



Do not wait for components to be deteriorated by use before proceeding with their replacement. Replace a worn component before it is completely broken to prevent any damage caused by sudden component breakage.

PARTS / FREQUENCY	60- 90 DAYS	1 SEASON
Inspection hatch	•	
Deep combustion chamber cleaning	•	
Door gasket		•
Chimney		•

Schedule the above extraordinary maintenance activities with the Authorised Assistance Centre.

### Deep combustion chamber cleaning

### ! IMPORTANT

This operation must be carried out by a Ravelli Assistance Centre. Schedule this type of cleaning with the Ravelli Assistance Centre.

To clean the combustion chamber, proceed as follows:  
1- Remove the vermiculite stop

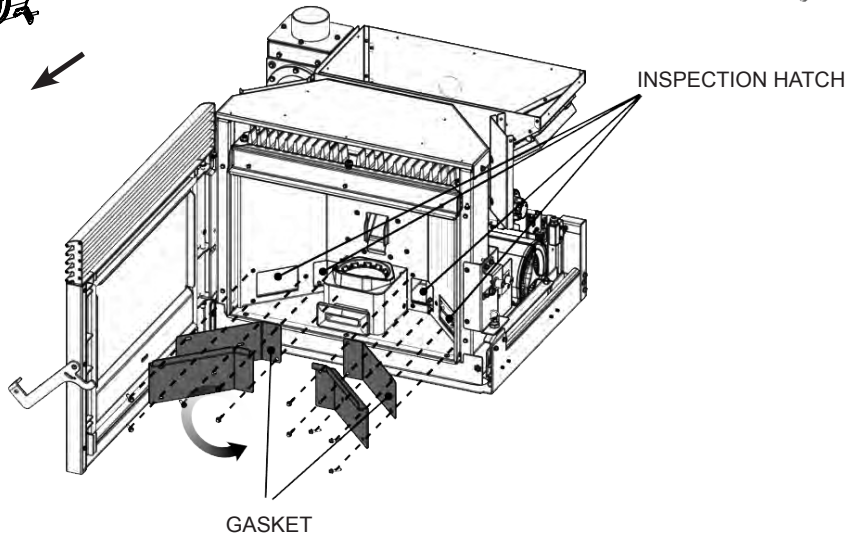
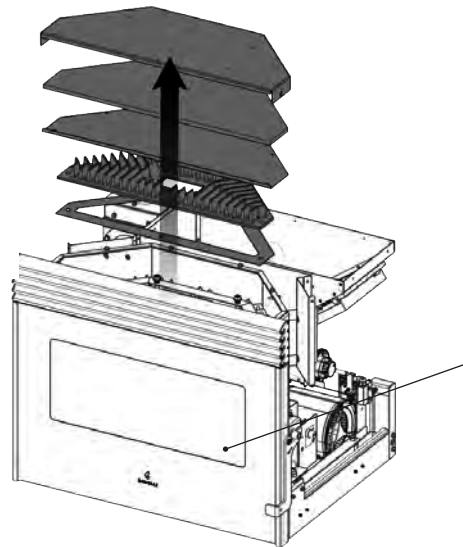
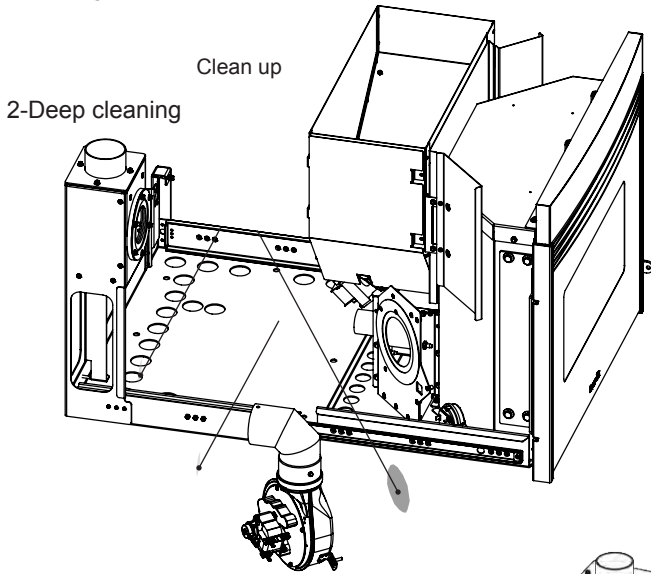
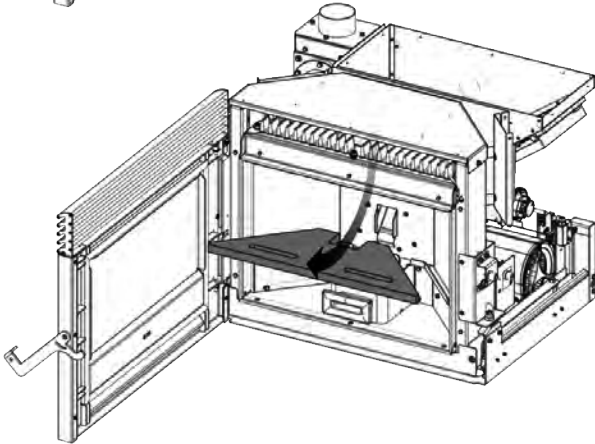
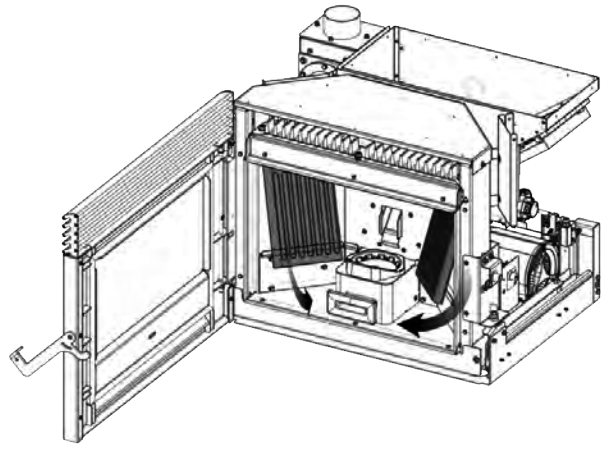
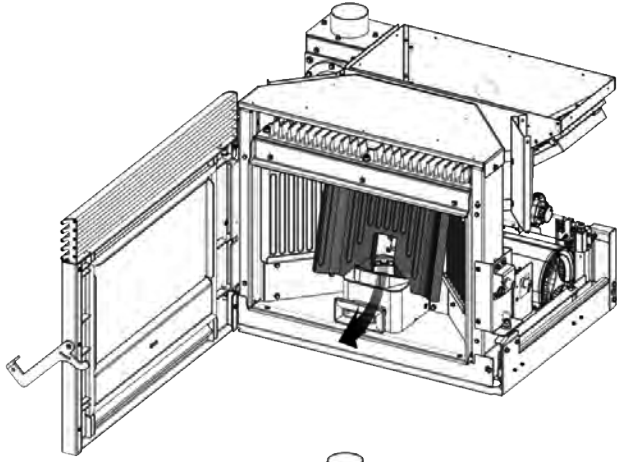

**Note:** The operation must be carried out with a cold stove, using an ash-type aspirator.

## 5.7 End of Season

At the end of every season we recommend vacuuming out any ash and dust that may still be inside.

## 5.8 Trouble Shooting

### ***The stove does not work***

- closely follow the directions in the dedicated chapter of this manual.
- make sure that the air intake duct is not obstructed;
- make sure that the smoke evacuation system is clean and not obstructed;
- make sure the chimney is sized for the stove power;
- make sure that the air intake in the room is clear of any obstructions and that there are no other combustion appliances or extraction hoods that create a vacuum in the room;

### ***Difficult lighting***

- closely follow the directions in the dedicated chapter of this manual;
- make sure that the air intake duct is not obstructed;
- make sure that the smoke evacuation system is clean and not obstructed;
- make sure the chimney is sized for the stove power.
- make sure that the air intake in the room is clear of any obstructions and that there are no other combustion appliances or extraction hoods creating a vacuum in the room.

### ***Smoke leakage***

- Check the draught of the chimney.
- Check whether the seals on the door, drawer and smoke evacuation system are intact.
- Make sure there is no ash obstructing the primary air flow grille.

### ***The glass gets dirty easily***

- Only use recommended fuels.
- Check the draught of the chimney.

## 6. Operating your Pellet Fire

### 6.1 Description of the Handheld Set

The handheld set is shown in the picture below:

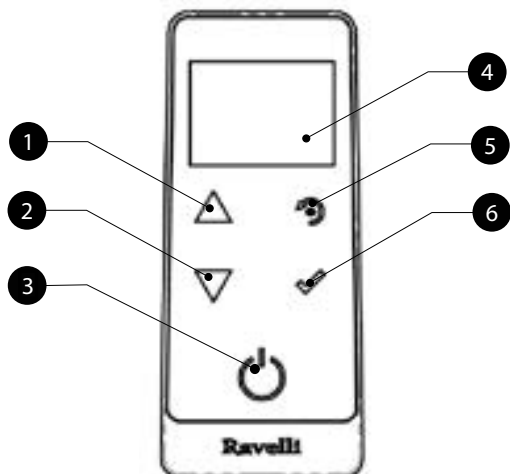

- |   |  |
|---|--|
| 1 | Increase button "UP" (selection key)   |
| 2 | Decrease key "DOWN" (selection key)    |
| 3 | ON/OFF or reset from "Sleep" mode key. |
| 4 | Display                                |
| 5 | Key for accessing the MENU and back    |
| 6 | Confirmation key                       |



*In "Sleep" mode, the handheld set screen is obscured, keeping however active the radio communication with the stove to reduce battery con-*

The information below will allow you to become familiar with the product and achieve the best performance.

#### **How to insert the batteries in the handheld set:**

Remove the protective cover of the battery on the back of the remote control as shown in Figure A, and insert the 3 batteries (mini pen style battery AAA 1.5v) in the housing of the handheld set and observe the poles. Install the battery protective cover as shown in Figure B



**Figure A**



**Figure B**

The handheld set, after a short screen showing the Ravelli logo, will list the languages available in the menu.



Select the desired language using the scroll keys and confirm your selection with the confirmation button.

### 6.2 Handheld touch radio initialization

In order to operate correctly, the handheld set should be interfaced with the electronic board installed inside the stove. For this reason, on display appears the following message:

If the handheld set is used for the first time, select YES using the selection keys and confirm with the dedicated key. On the display of the handheld set appears the following:



Hold down for a few seconds the button of radio communication (RADIO ADJ) of the PCB, located on the back of the stove, to initialize the device.

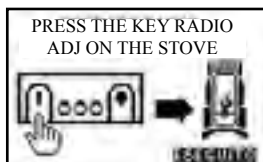

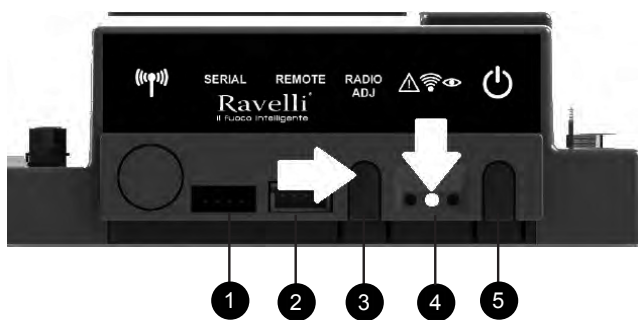

- 1 Serial port
- 2 Handheld cable connection socket
- 3 ADJ radio: button to connect your handheld to the board
- 4 Signalling LED  
Red: active alarm  
Yellow: Waiting communication with the handheld set  
Green: Cooker switched on
- 5 Cooker ON/OFF key

The flashing yellow LED indicates that the circuit board is waiting to receive the signal from the handheld set. By pressing the enter key on the handheld set, the components start communicating with each other. A check sign on the display, accompanied by a sound signal, shows that the initialization of the handheld set has been completed successfully



**i** When you replace the batteries, you do not have to run the initialization procedure of the handheld set. In this case, when on display appears the message "FIRST INSTALLATION ?", select **NO** and press the confirmation key.

### 6.3 Description of the display

The display of the handheld set is described below (in stand-by mode):

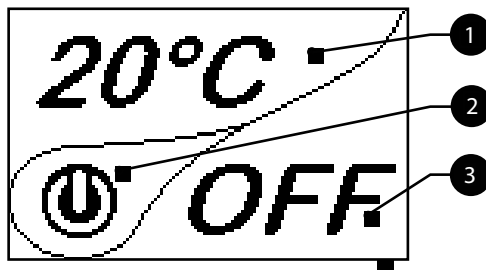

**i** After 5 minutes of inactivity, the display of the handheld set turns dark, switching to "SLEEP" mode, while maintaining the radio connection with the stove. By pressing the key ON/OFF, the display becomes active again.

**i** The first pressure of any key with the display active lights up its backlight, but it is not, however considered a command.

**The display is subdivided into three parts:**

**1** It shows the current room temperature measured by the handheld set. Moreover, if you press the DOWN scroll key you will display the temperature settings that can be changed using the two UP/DOWN keys. Any change made is confirmed automatically within 3 seconds from the change or by pressing the confirmation key. A sound signal indicates that the change has been confirmed.



**2** Icon indicating the status of the stove (see synthetic phase diagrams).

**3** In the inactive phases (combined with the second part of the display) indicates the state of the stove. In the active phases, it indicates the operating power of the stove.

In addition, by pressing the DOWN scroll button, you can display the power settings, that can be edited using the two scroll keys UP/DOWN: The confirmation of any change takes place automatically within 3 seconds from the change or by pressing the confirmation key. A sound signal indicates that the change has been confirmed.





## 6.4 Time and date setting

Below are given the steps for accessing the relative menu.

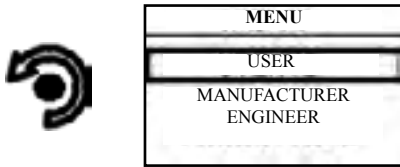

Press the key "access menu" to access the MENU page

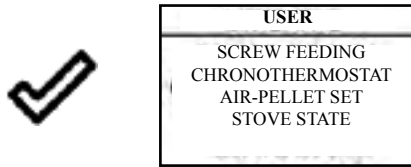

Press the key "confirm" to access the USER page

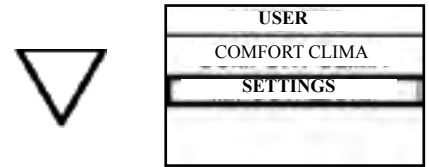

Press the key "selection" for "selection" to switch to the second page of USER MENU and select SETTINGS.

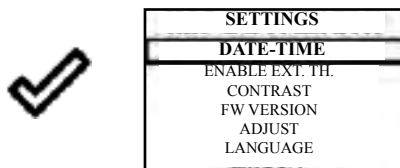

Press the key "confirm" to access the SETTINGS page

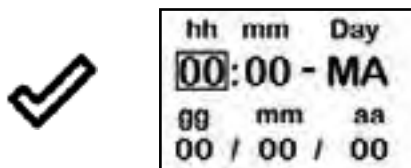

Press the key "confirm" to access the DATE-TIME page

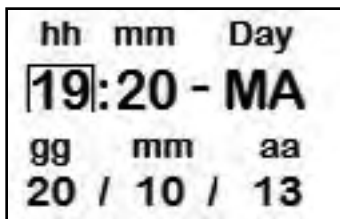

Press the increase key to change every single value



Press the decrease key to change every single value



Press "confirm" to confirm the settings and switch to the next value.



By pressing the key "back" for several times you will display the stand-by page.

## 6.5 Loading the Auger



Carry out this operation to facilitate stove's first start operations; You should also check that you have introduced pellets into the hopper and wait until the stove is in "SHUTDOWN" or "FINAL CLEANING" mode. The number expressed in seconds indicates the rotation time of the infeed screw during the first loading cycle. Once this time has elapsed, the infeed screw stops immediately and then pellets are emptied from the grate before turning on the equipment.

Below are given the steps for accessing the relative menu.

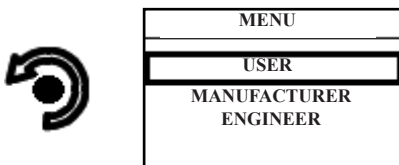

Press the key "access menu" to access the MENU page

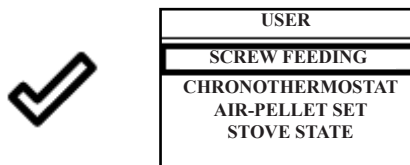

Press the key "confirm" to access the USER page

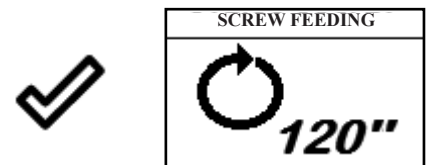

Press CONFIRM to enable the rotation of the auger

At the end of the auger loading, the display shows 0 "and automatically switches to the USER menu page.



Press the key for several times until the Stand-by page is displayed.



ALWAYS EMPTY THE BRAZIER BEFORE TURNING THE STOVE ON AND ALWAYS CHECK THAT ALL NONE OF ITS HOLES IS CLOGGED NEVER EMPTY THE RBAZIER INSIDE THE HOPPER. FIRE HAZARD.

## 6.6 Setting Operating Temperature and Power:

Set the two values following the indications given in the chapter "Description of the display"

## 6.7 Turning the Device on:

Keep the key ON/OFF pressed for a few seconds to turn on the stove.



The appearance of the message "ADJUST THE RDS SYSTEM" indicates that the initial parameter testing procedure and calibration has been unsuccessfully. This indication does not cause stove blockage (see the WARNING POP UP section).

On the display of the handheld set appears the following:



Press and hold the ON/OFF button to turn off the stove door, and reset any alarms triggered.



In case the infeed screw operations described above have not been executed, the stove may fail to turn on. In this case, carry out the operations described above and empty the brazier and reset the alarm.

If the stove still fails to turn on, check that the grate is properly installed and perfectly adherent to the base, and also check that there are no deposits that prevent the smooth passage of air to enable ignition. If the problem persists, contact the support service.

### Sequence of ignition phases



SWITCH-ON- initial pellet loading phase;  
WAIT FLAME - flame development wait phase;

FLAME PRESENT - flame stabilization phase and reduction of combustible inside the brazier;



WORK - operation phase described in the dedicated chapter;

### What happens if the batteries are empty?



If the battery is discharged, within the "drop" is shown a symbol that indicates that the battery is empty, while maintaining active the features of your device.

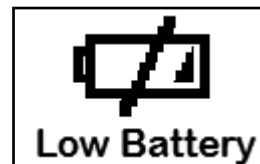

As soon as the level of the battery prevents the radio communication the handheld set displays on full screen the picture of empty battery and all device functions are locked until the batteries are replaced

## 6.8 Operating Phases of the Appliance

### Modulation

During the work phase, the appliance should reach the room temperature set; when this condition is met, the stove switches to MODULATION mode in which fuel consumption and ventilation are minimum.

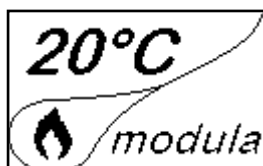

If you wish to detect the ambient temperature by means of an external thermostat (optional), this must be connected to the appropriate connector on the rear side of the stove; and you will have to activate the reading in "SETTINGS - EN - ABLE THERMOSTAT." On display appears the writing TON / TOFF based on thermostat request.



CONNECT AN EXTERNAL THERMOSTAT WITH A SIMPLE DRY CONTACT, THEREFORE, NOT POWERED. MOREOVER, WE RECOMMEND YOU USE A THERMOSTAT WITH A MINIMUM OFFSET OF 3°C IF YOU INTEND TO USE THE COMFORT CLIMA FUNCTION.

### Comfort climate

The activation of this function enables the stove to reduce pellet consumption by activating the modulation phases, after the desired temperature has been reached. Subsequently, the stove checks that the temperature is maintained steady for a preset time. If this condition is met, it automatically switches off, and on display appears the writing ECO. The stove turns on again when the temperature drops below the set threshold.

Below are given the steps for accessing the relative menu.

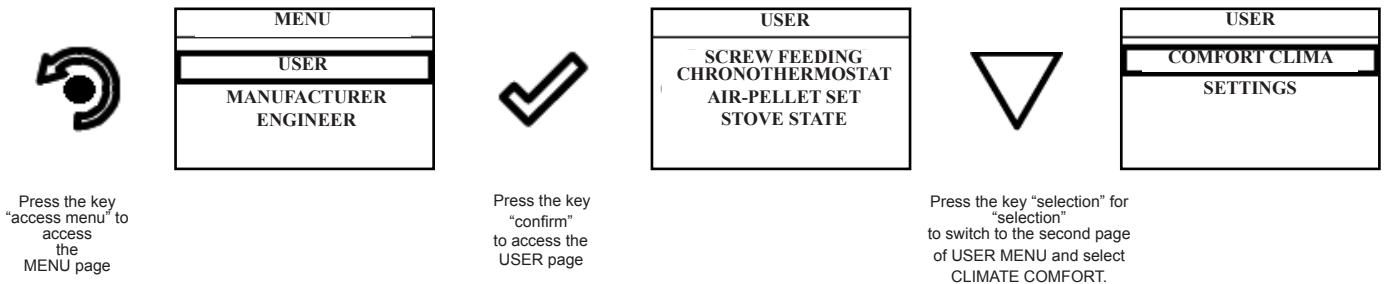

Once you have accessed the Climate Comfort menu, it is possible to operate on the 3 types of settings dedicated to the function:

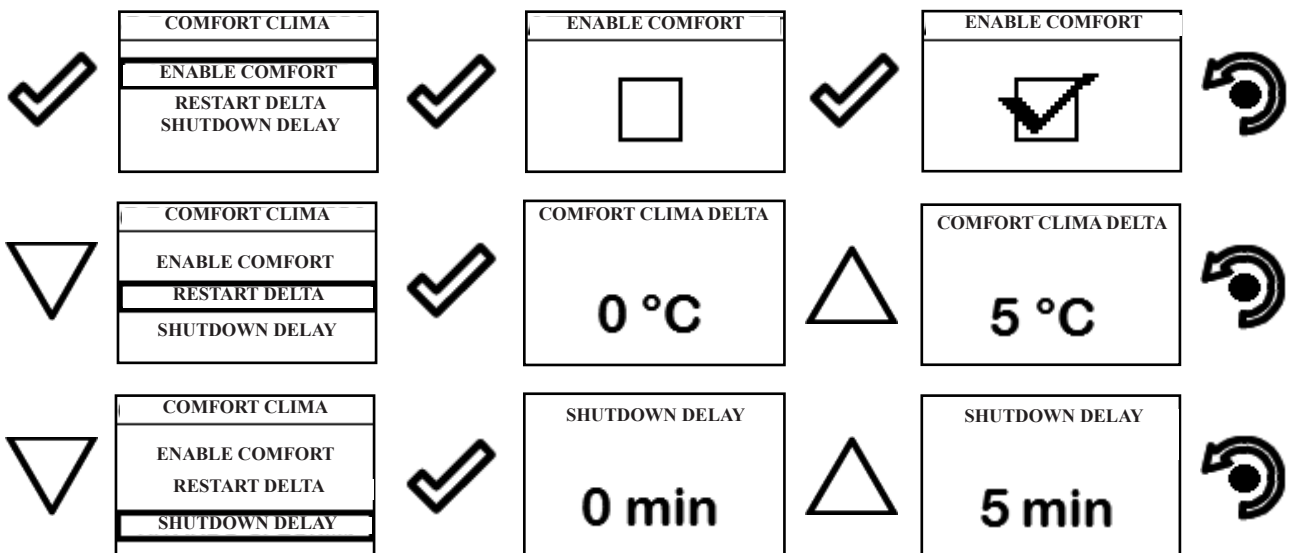

Press the key for several times until the Stand-by page is displayed.

The first setting allows the activation of the CLIMATE COMFORT function. This function is intended to ensure that the room temperature set is maintained steady upon setting the maximum period of "X" minutes (SWITCH-OFF DELAY: 5 MIN) before switching to ECO STOP phase. The STOVE maintains this state until the temperature drops below the set value (CLIMATE COMFORT DELTA : 5).

For example, with the room temperature at 21 ° C, the stove switches off when this temperature is reached and restarts when the temperature reaches 15°C (21°C - 5°C - 0,5°C tolerance).

You can also activate the function using an external thermostat, keeping in mind that this does not include the value of the hysteresis.



*We recommend you use an external thermostat with a hysteresis value that can be set to maximum 3° C. The operation of the stove could activate the switch ON/OFF phases for several times during the day; this may affect the service life of the ignition coil.*



**USING THIS METHOD, IT IS NECESSARY TO VERIFY THAT AFTER EACH AUTOMATIC SHUTDOWN THE GRATE IS ALWAYS VERY CLEAN TO GUARANTEE CORRECT AUTOMATIC SWITCH ON.**

## Description of menu functions



Press the key to access the MENU page

MENU
USER MANUFACTURER ENGINEER



The **TECHNICIAN** and **MANUFACTURER** menus are protected by password.

## Chronothermostat

With the Chrono-thermostat function you can program the automatic switch ON/OFF of the stove for each day of the week for each day of the week in 4 independent time intervals (SET CHRONO 1-2-3-4)

Below are given the steps for accessing the relative menu starting from Stand-By mode.



MENU
USER MANUFACTURER ENGINEER



USER
SCREW FEEDING CHRONOTHERMOSTAT AIR-PELLET SET STOVE STATE



USER
SCREW FEEDING CHRONOTHERMOSTAT AIR-PELLET SET STOVE STATE

Press the key "access menu" to access the MENU page

Press the key "confirm" to access the USER page

Press the key "selection" to quickly switch to CRONO-THERMOSTAT.



CHRONO
ENABLE CHRONO
SET CHRONO 1
SET CHRONO 2
SET CHRONO 3
SET CHRONO 4



ENABLE CHRONO
<input type="checkbox"/>



ENABLE CHRONO
<input checked="" type="checkbox"/>



CHRONO
ENABLE CHRONO
SET CHRONO 1
SET CHRONO 2
SET CHRONO 3
SET CHRONO 4



00,00	00,00
LU MA ME GI VE SA DO	
<input type="checkbox"/> <input type="checkbox"/> <input type="checkbox"/> <input type="checkbox"/> <input type="checkbox"/> <input type="checkbox"/> <input type="checkbox"/>	
5	21

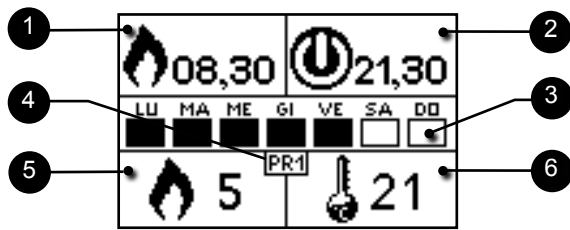

- |   |                                      |
|---|--------------------------------------|
| 1 | Settable switch-on program           |
| 2 | Settable switch-off program          |
| 3 | Day of the week with active program  |
| 4 | Number of "chrono" program (1-2-3-4) |
| 5 | Setting the power upon programming   |
| 6 | Setting ambient temperature          |



By pressing the Increment key you can change each value and, at step 3, enable the days of the week;



By pressing the Decrement key you can change each value and, at step 3, enable the days of the week;



Press "confirm" to confirm the settings and switch to the next value;



Press the "back" button to return to the CHRONO-THERMOSTAT page.

As per the above example, it has been set as CHRONO 1 an ignition from 08.30 to 21.30 from MONDAY to FRIDAY at the operating power 5 with a room temperature set at 21 ° C. Programmes 2-3-4 can be set in the same manner.



To exit the CHRONO-THERMOSTAT function and return to Stand-by page, press the button repeatedly.

#### AIR / PELLETS setting

Setting of the PELLET-FLOW mix enables you to immediately change the quantity of pellet loaded in the brazier and the air inflow. The stove is tested and inspected with DIN PLUS certified pellets. If using another type of pellets or uncertified pellets, fuel may need adjustment. Usually, the variation involves the FLOW percentage to adjust the input air and, therefore, the combustion; should the regulation of flow be insufficient, it may be necessary to also change the percentage of PELLET load.

Below are given the steps for accessing the relative menu starting from Stand-By mode.

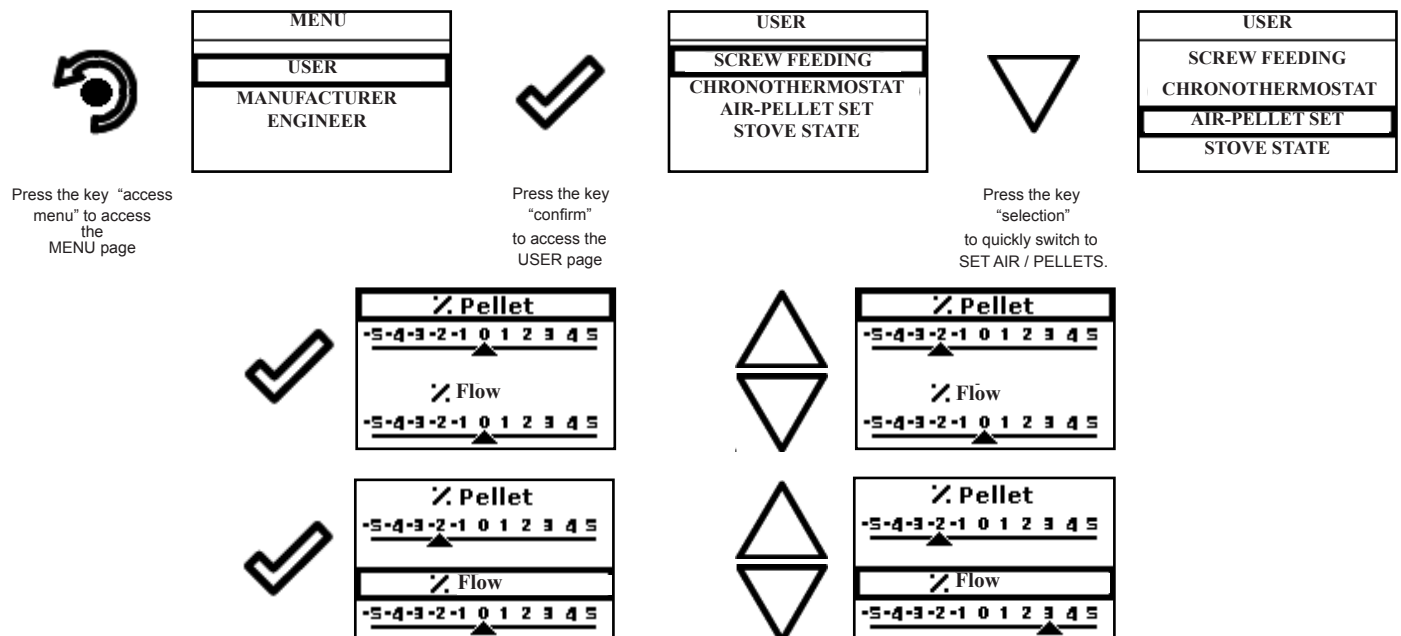

As per the above example, you have set a percentage of -2 for PELLETS and +3 for the FLOW, an indication that a setting like this is a consequence of the fact that the oxygen needed for combustion is insufficient and pellet size is smaller than the average size of 2 cm.



To exit the SET AIR - PELLET function and return to Stand-by page, press the button repeatedly.



**NOTE:** The number indicated during the change of parameters refers only to a percentage value that acts on the default parameters set on the electronic board (exclusively in the WORK phase). These values should be changed in the event of poor combustion, due in many cases to the purchase of pellets differing from those used during stove testing.

**Stove State**

Below are given the steps for accessing the relative menu starting from Stand-By mode.

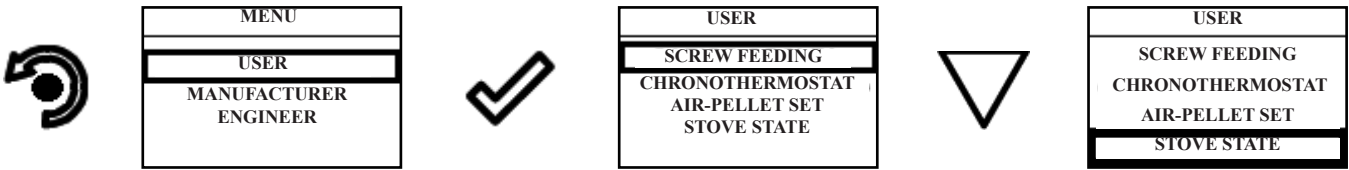

Press the key "access menu" to access the MENU page

Press the key "confirm" to access the USER page

Press the key "selection" to quickly switch to STOVE STATE.

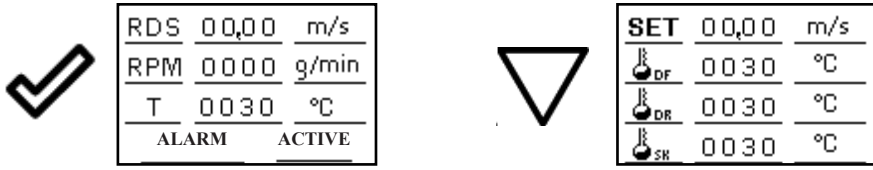

In this mode you can check the proper operation of the most important parameters of the appliance. Below is a list of real data of the stove useful for service during inspection.

- Actual flow
- Fume extractor revolutions;
- Fume temperature;
- Stove state:
- Actual flow set;
- Inlet flow meter temperature;
- Heated flow meter temp.;
- Electronic board temperature;

To exit the STOVE STATE page and return to Stand-by page, press the button repeatedly.

**Settings > Enable thermostat**

Below are given the steps for accessing the relative menu starting from Stand-By mode.

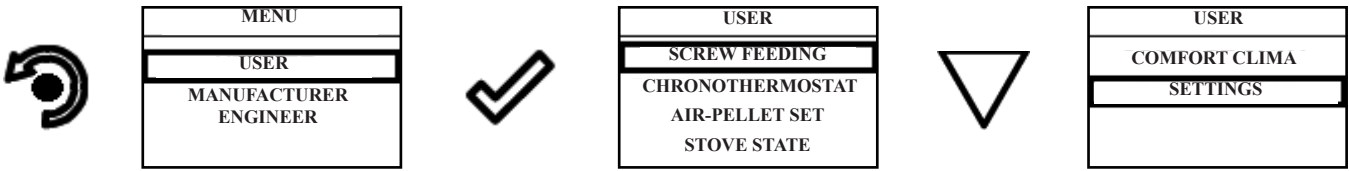

Press the key "access menu" to access the MENU page

Press the key "confirm" to access the USER page

Press the key "selection" to quickly switch to the second page of the menu SETTINGS.

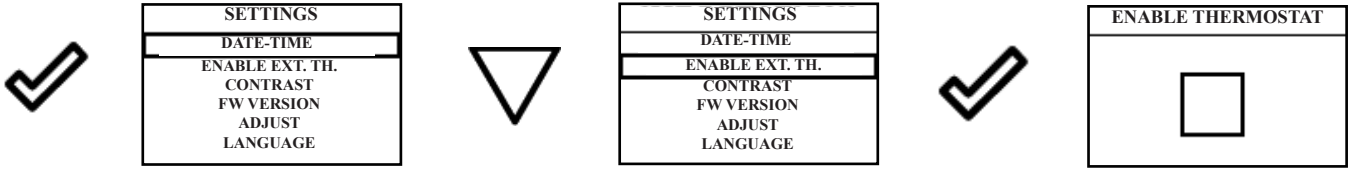

Press the key "confirm" to access the SETTINGS page

Press the key "selection" to switch to the function

Press the key "confirm" to access the function

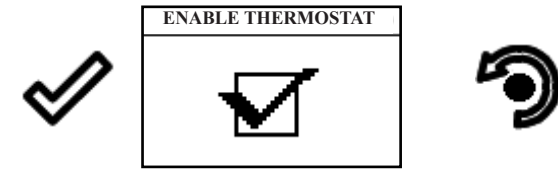

Press the key "confirm" to enable the function.

ENABLE THERMOSTAT. By repeatedly pressing the key you will go back to the "STAND BY"



*In Stand-By mode, instead of the measured and settable ambient temperature appears the line T ON if the room where the thermostat is installed has not yet reached the requested value or the writing T OFF if the room temperature set has been reached.*

## Settings

Below are given the steps for accessing the relative menu starting from Stand-By mode.



MENU
USER
MANUFACTURER
ENGINEER



USER
SCREW FEEDING
CHRONOTHERMOSTAT
AIR-PELLET SET
STOVE STATE



USER
COMFORT CLIMA
SETTINGS

Press the key "access menu" to access the MENU page

Press the key "confirm" to access the USER page

Press the key "selection" to quickly switch to the second page of the menu

After following the procedure above step by step, you can set the following functions:

### Settings > Contrast



SETTINGS
DATE-TIME
ENABLE EXT. TH.
CONTRAST
FW VERSION
ADJUST
LANGUAGE



SETTINGS
DATE-TIME
ENABLE EXT. TH.
CONTRAST
FW VERSION
ADJUST
LANGUAGE



CONTRAST
50

Press the key "confirm" to access the SETTINGS page

Press the key "selection" to switch to the function CONTRAST.

SETTINGS. Press the key "confirm" to access the function



Use the UP/DOWN keys to change contrast setting and obtain a better visualisation of the information shown on the handheld set. The value can vary from 0 to 100. 50 with respect to



By pressing the following button you will confirm the data and switch to the page within the SETTINGS menu.

### Settings > Firmware version



SETTINGS
DATE-TIME
ENABLE EXT. TH.
CONTRAST
FW VERSION
ADJUST
LANGUAGE



SETTINGS
DATE-TIME
ENABLE EXT. TH.
CONTRAST
FW VERSION
ADJUST
LANGUAGE



FIRMWARE
AIR_TOUCH_MB01.00
STREAMER
AIR_TOUCH_UI01.00

Press the key "confirm" to access the SETTINGS page

Press the key "selection" to switch to the function CONTRAST.

Press the key "confirm" to access the function



By pressing the following button you will confirm the data and switch to the page within the SETTINGS menu.

### Settings > Adjust



SETTINGS
DATE-TIME
ENABLE EXT. TH.
CONTRAST
FW VERSION
ADJUST
LANGUAGE



SETTINGS
DATE-TIME
ENABLE EXT. TH.
CONTRAST
FW VERSION
ADJUST
LANGUAGE



ADJUST
0° C

Press the key "confirm" to access the SETTINGS page

Press the key "selection" to switch to the function VERSION FW.

Press the key "confirm" to access the function

















Use the UP/DOWN keys to change the value read by the room temperature probe installed inside the handheld set, with respect to a reference value. The value can vary from -10°C to 10°C. The standard value is 0°C.

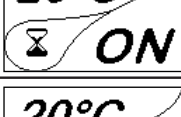

By pressing the following button you will confirm the data and switch to the page within the SETTINGS menu.

### Stove phase synthetical layout

	PHASE	DESCRIPTION
	FINAL CLEANING	The stove is in the switch off phase and the cooling phase has not been completed yet.
	SWITCH ON	The heater pre-heating phase has started and the pellets start to fall into the grate.
	WAITING FOR FLAME	The pellets ignite and take advantage of the heat in the intake air that passes through the incandescent heater tube.
	FLAME PRESENT	The flame is visible in the grate.
	AREAS	The stove has completed the switch on phase and runs at maximum set capacity.
	WORK MODULA	The room temperature set has been reached.
	THE GRATE	Brazier cleaning phase is active (periodic function).
	ECO STOP	With Climate Comfort active, the stove switches to automatic switch-off mode when the room temperature set is reached (see the dedicated section).
	START/RESTART WAIT	Switch-on is requested but with the stove in cooling phase; once this condition is met, it restarts automatically.
	SWITCH ON RESTART	The HOT restart phase is activated. Functioning is similar to the SWITCH ON phase
	HOT SMOKE	The maximum fume temperature threshold has been reached. To facilitate cooling, the stove brings the capacity to a minimum with ventilation at power level 5, leading to a decrease in fume temperature.
	OFF	The stove is off
	WAIT FOR PELLETS OUT OF	When the switch-on request from ECO-STOP mode coincides with an automatic switch-off condition (from the TIMER), the stove turns on ensuring total cleaning of the brazier before switching to FINAL CLEANING.
	INFEEED SCREW OVERFLOW	CONDITION: when the pellet setting (set pellets +5) is near the continuous load condition. SOLUTION: Set the value back to 0.

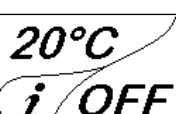

 <b>AL-05</b>	<b>GENERIC ALARM</b>	The stove is in alarm state; refer to the troubleshooting chapter.
	<b>ANOMALY (general)</b>	The stove has detected an anomaly; refer to the troubleshooting chapter.

### Warning Pop-Up

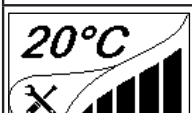
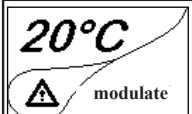
	FLAME	DESCRIPTION
 Adjust RDS system	<b>RDS SYSTEM ADJUSTMENT REQUEST</b> <i>(only if the RDS system is provided)</i>	It shows that the testing procedure and initial parameter calibration have not been completed or have been performed incorrectly. This indication, however, does not block the stove.
	<b>SERVICE REQUEST</b>	The threshold value of set work hours has been reached. The symbol displayed remains active throughout the work phase. Non-routine maintenance is required on the stove.
	<b>AIR FLOW METER FAILURE</b> <i>(only if the RDS system is provided)</i>	It shows a failure of the air flow meter and the stove switches to minimum capacity disabling the RDS system.

SIGNALLING	REASON	SOLUTION
<b>RUN BRAZIER CLEANING</b> <i>(only if the RDS system is provided)</i>	• The door and the ash box are not closed correctly	• Make sure they are properly closed.
	• Poor combustion in grate.	• Switch off the stove, clean the brazier and check the cleanliness of the support bench, clean the tube bundle by activating the turbolators. and adjust the combustion through Pellet/Air settings.
	• Presence of foreign body in air intake tube.	• Check for any foreign body and remove it
	• The air flow meter may be dirty.	• Clean the flow meter with the stove in "Switched off" state • Contact the Support Service



The appearance of the message "ADJUST THE RDS SYSTEM" indicates that the initial parameter testing procedure and calibration has been unsuccessfully. This indication does not block the stove.

### 6.9.1 Alarms (table with reference codes)

TRIAL	TITLE	REASON	SOLUTION
AL 01	BLACK OUT	- No voltage during work phase	- Press the switch off key and switch on boiler switch-on.
			- If the problem persists, contact the Support Service
AL 02	FUME PROBE	- The fume probe is malfunctioning	- Contact the Support Service
		- The fume probe is disconnected from the electronic board	- Contact the Support Service
AL 03	FUME OVERTEMP.	- Combustion in the brazier is not optimal due to clogging or obstructions of internal stove ducts	- Switch off the stove, clean the brazier and the tube bundle and adjust the combustion setting the Pellet/Air values
		- The tangential fan (if provided) is malfunctioning or damaged	- Contact the Support Service
			- If the problem persists, contact the Support Service
AL 04	FUME EXHAUST DAMAGED	- Fume exhaust encoder is not working or is connected incorrectly	- Contact the Support Service
		- No power to fume exhaust system	- Contact the Support Service
		- The fume exhaust system is blocked	- Contact the Support Service
AL 05	NO SWITCH-ON	- The pellet tank is empty	- Check for the presence of pellets in the container. Top up, if necessary.
		- Pellet calibration and suction during switch on phase is incorrect.	- Contact the Support Service
		- The ignition coil is faulty or positioned	- Contact the Support Service

AL 06	PELLETS FINISHED	- The pellet tank is empty.	- Check for the presence of pellets in the container. Top up, if necessary.
		- The gear motor is not loading pellets	- Empty the tank to see if there are any objects inside that may prevent the proper operation of the auger.
		- Not enough pellets loaded	- Regulate pellets setting from "SET AIR/PELLETS"
			- If the problem persists, contact the Support Service Support
AL 07	RESET THERMAL BREAKER / PELLET DOOR OR GATE OPEN	- The manual reset thermostat has tripped connected to the hopper (RESET THERMAL BREAKER / Pellet door or gate is open	- Reset the thermostat by pressing the button on the back of the stove or close the doors.
		- Combustion in the grate is not optimal due to the fact that the grate is clogged or the inner stove ducts are clogged. (RESET THERMAL BREAKER)	- Switch off the stove, clean the brazier and the tube bundle and adjust the combustion setting the Pellet/Air values
			- Contact the Support Service
AL 08	DEPRESSURIZATION	- The flue is blocked.	Check the flue is free and clean
		- The vacuum meter is faulty.	- Contact the Support Service
AL 12	FUME EXHAUST SYSTEM FAILURE	- The fume exhaust system has a loss of performance due to fan obstruction or voltage drop.	- Contact the Support Service
AL 14	SCREW PHASE	- No cable connection to power the gear motor of the auger	- Contact the Support Service
AL 15	AUGER TRIAC	- An internal part of the electronic board that controls the pellet infeed screw is faulty.	- Contact the Support Service
		- Possible voltage drops or incorrect input voltage stove inlet	- Check the mains voltage.
AL 17	NO FLOW <i>(only if the RDS system is provided)</i>	- The flow meter does not measure inlet air flow	- Check if the ash pan and door are closed correctly and check if the air inlet pipe is obstructed.
			- If the problem persists, contact the Support Service

Positions of the switch protected by a screw cap and of the reset safety thermostat located on the side.

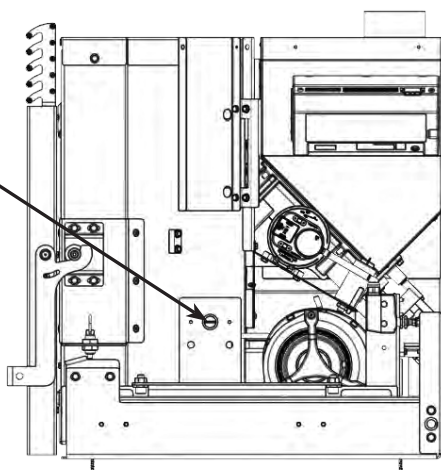

**7. Maintenance Record**

DATE	WORK CARRIED OUT	SIGNATURE

## 8. Warranty Information

Pellet Fire Solutions and its partner Ravelli, manufacturers of the Ravelli range of pellet fires extends the following warranty for their wood pellet fires when purchased from an authorised Pellet Fire Solutions dealer.

### 8.1 Warranty Coverage

Pellet Fire Solutions warrants to the original owner of the pellet fire at the site of installation, and to any transferee taking ownership of the pellet fire at the original site of installation within two years following the date of original purchase, that the pellet fire will be free from defects in materials and workmanship at the time of manufacture. After installation, if any covered components manufactured by Ravelli are found to be defective in materials or workmanship during the applicable warranty period, Pellet Fire Solutions will, at its option, repair or replace the covered components. Pellet Fire Solutions, at its own discretion, may fully discharge all of its obligations under such warranties by replacing the product itself or refunding the verified purchase price of the product itself. The maximum amount recoverable under this warranty is limited to the purchase price of the product. This warranty is subject to conditions, exclusions and limitations as described below.

This warranty only covers pellet fires that are purchased and installed through an authorised Pellet Fire Solutions dealer or distributor. A list of authorised dealers is available on the Pellet Fire Solutions website ([www.pelletfiresolutions.co.nz](http://www.pelletfiresolutions.co.nz)).

This warranty is only valid while the pellet fire remains at the site of original installation.

Contact your installing dealer for warranty service. If the installing dealer is unable to provide necessary parts, contact the nearest authorised Pellet Fire Solutions dealer or supplier. Additional service fees may apply if you are seeking warranty service from a dealer other than the dealer from whom you originally purchased the product.

Check with your dealer in advance for any costs to you when arranging a warranty call. Travel and shipping charges for parts are not covered by this warranty.

### 8.2 Warranty Period

Warranty coverage begins at the date of installation. In the case of new home construction, warranty coverage begins on the date of first occupancy of the dwelling, or six months after the sale of the product by an independent, authorised, Pellet Fire Solutions dealer/distributor, whichever occurs earlier. The warranty period for parts and labour for covered components is explained in the following table.

Component(s)	Parts	Period	Comments
Fireplace, stovebody and parts covering: Firebox, Heat exchanger Pedestals, Panels & Legs	Full replacement	5 years parts 2 years labour	Surface finishes, burnpot liner and ceramic panels are covered separately (see clarifications and exclusions below).
<b>Electrical items covering</b>			
Ignitor (including tube) Auger Motor Circuit Board, Blowers (Convection and Combustion) Timers Sensors Vacuum Switch Wire harness	Full replacement	2 years parts & labour	
<b>Replacement/spare Parts</b>			
All replacement parts beyond their original warranty period or purchased new from a Dealer	Full replacement	1 year parts only	Evidence of the original purchase date will be required e.g. a copy of the original invoice.
<b>Clarifications and exceptions</b>			
Burnpot Liner and Brick Liner	Full replacement	1 years parts & labour	Paint on the brick firebox lining may peel over time due to the extreme conditions and is not a flaw.
Exterior surface finishes (including plating, enamel or paint)	Full replacement	1 years parts & labour	Colour changes with heating and tarnish, discolourisation and wear (including scratches, fingerprints etc.) are not covered under warranty.
<b>Exclusions</b>			
Glass			No warranty
Vermiculite (Firex 600) & ceramic panels (cast majolica)			No warranty
Fibreglass rope gaskets			No warranty

### 8.3 Warranty Exclusions

This warranty does not cover the following:

- Changes in surface finishes as a result of normal use. As a heating appliance, some changes in colour of interior and exterior surfaces may occur. This is not a flaw and is not covered under warranty.
- Damage to printed, plated, or enamelled surfaces caused by fingerprints, accidents, misuse, scratches, melted items, or other external sources and residues left on the plated surfaces from the use of abrasive cleaners or polishes.
- Repair or replacement of parts that are subject to normal wear and tear during the warranty period. These parts include: paint, gaskets, FIREX, flame guides, and the discolouration of glass.
- Minor expansion, contraction, or movement of certain parts causing noise. These conditions are normal and complaints related to noise are not covered by this warranty.
- Damages resulting from: (1) failure to install, operate or maintain the pellet fire in accordance with the installation instructions, operating instructions and data plate furnished with the pellet fire; (2) failure to install the pellet fire in accordance with local building codes; (3) shipping or improper handling; (4) improper operation, abuse, misuse, continued operation with damaged, corroded or failed components, accident, or improperly/incorrectly performed repairs; (5) environmental conditions, inadequate ventilation, negative pressure, or drafting caused by tightly sealed constructions, insufficient make-up air supply, or handling devices such as exhaust fans or forced air furnaces or other such causes; (6) use of fuels other than those specified in the operating instructions; (7) installation or use of components not supplied with the pellet fire or any appliance not expressly authorised and approved by Pellet Fire Solutions / Ravelli; (8) modification of, interruptions to or fluctuations of the electrical power supply to the pellet fire.
- Non Pellet Fire Solutions approved venting components, hearth components or other accessories used in conjunction with the appliance.
- Any part of a pre-existing fireplace system
- Pellet Fire Solutions / Ravelli's obligation under this warranty does not extend to the pellet fires' capability to heat the desired space. Information is provided to assist the consumer and the dealer in selecting the proper appliance for the application. Consideration must be given to appliance location and configuration, environmental conditions, insulation and air tightness of the structure.

The warranty is void if:

The pellet fire has been over-fired or operated in atmospheres contaminated by chlorine, fluorine, or other damaging chemicals. Over firing can be identified by, but not limited to, warped plates or tubes, rust coloured cast iron, bubbling, cracking and discolouration of steel or enamel finishes.

The pellet fire is subjected to prolonged periods of dampness or condensation.

There is any damage to the pellet fire or other components due to water or weather damage which is the result of, but not limited to, improper chimney or venting installation.

The owner's exclusive remedy and Pellet Fire Solutions / Ravelli's sole obligation under this warranty, under any other warranty, express or implied, or in contract, tort or otherwise, shall be limited to replacement, repair, or refund, as specified above. In no event will Pellet Fire Solutions / Ravelli be liable for any incidental or consequential damages caused by defects in the appliance. Some countries do not allow exclusions or limitation of incidental or consequential damages, so these limitations may not apply to you. This warranty gives you specific rights, you may also have other rights, which vary from country to country. EXCEPT TO THE EXTENT PROVIDED BY LAW, Pellet Fire Solutions / Ravelli MAKES NO EXPRESS WARRANTIES OTHER THAN THE WARRANTY SPECIFIED HEREIN. THE DURATION OF ANY IMPLIED WARRANTY IS LIMITED TO DURATION OF THE EXPRESSED WARRANTY SPECIFIED ABOVE.

## 9. Proof of Purchase/Warranty

Use this page to note down the details of your wood pellet fire purchase, and attach the receipt and any other documents/business cards from the retailer that sold you the fire.

**Name of Store where Pellet fire was purchased:** .....

**Date of Purchase:** .....

**Amount Paid:** \$.....

**Payment Method:**                       Credit Card    EFTPOS    Cash    Other

**Attach receipt and other documents here**

## Installation Section - Table of Contents

<b>1. Dimensions Ravelli Corina.....</b>	<b>32</b>
<b>1.1 Deciding where to locate your wood pellet burning fire place.....</b>	<b>33</b>
<b>1.2 Floor Protection.....</b>	<b>33</b>
<b>2. Installation.....</b>	<b>34</b>
<b>2.1 Dimensions – Corina Built in Heater.....</b>	<b>34</b>
<b>2.2 Clearances &amp; Specifications .....</b>	<b>35</b>
<b>2.3 Positioning of the Corina Pellet Fire.....</b>	<b>36</b>
<b>2.4 Installation of the Corina Pellet Fire.....</b>	<b>36</b>
<b>2.5 Television Clearances.....</b>	<b>37</b>
<b>2.6 Example of Cavity Design.....</b>	<b>38</b>
<b>2.7 Seismic Restraint.....</b>	<b>40</b>
<b>2.8 Examples of Installation.....</b>	<b>41</b>
<b>2.9 Electrical Connection.....</b>	<b>42</b>
<b>2.10 Circuit Board Layout.....</b>	<b>43</b>
<b>2.11 Corina Built inFlue Kit (#58).....</b>	<b>44</b>
<b>2.12 Corina Built in Flue Kit (#58.1).....</b>	<b>45</b>
<b>3. Installation Data Sheet .....</b>	<b>46</b>
<b>4. Maintenance Record .....</b>	<b>47</b>
<b>Producer Statement and Warranty Registration Form...</b>	<b>48</b>

**NOTE TO INSTALLER - PLEASE ENSURE THE “INSTALLATION DATA SHEET” ON PAGE 45 IS COMPLETED ONCE THE UNIT IS INSTALLED.**

# 1. Dimensions Ravelli Corina



	Unit of Measurement	
Height	mm	704
Width	mm	885
Depth	mm	539
Weight	Kg	130
Diameter of smoke exhaust duct	mm	80
Min.-max.calorific power	kW	3.0 - 9.0
Min.-max. hourly consumption of pellets	Kg/h	0.6 – 1.45
Electrical power absorbed during operation	W	240
Supply	V - Hz	220 – 50
Tank capacity	Kg	20
Space Heating Efficiency	%	84

The data shown above are indicative and not binding. Ravelli reserves the right to make any modifications for the purpose of improving the performances of the product.

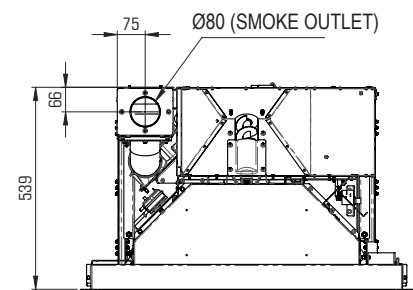
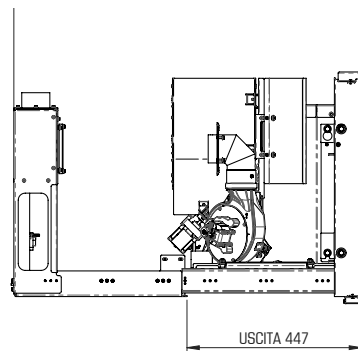
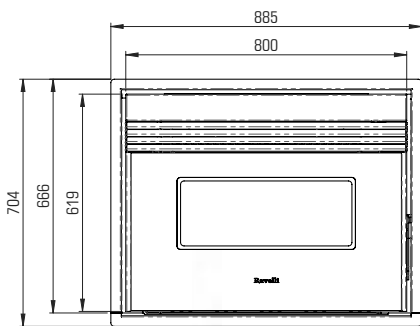

**\* CHIMNEY EXTRACT ROUND 450 MM**

*New Build*

*New Build*

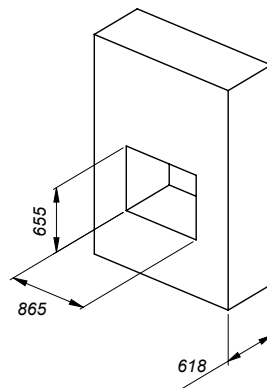
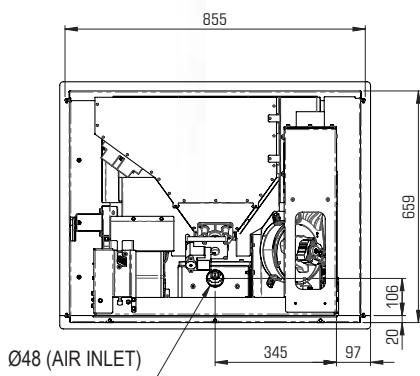



## 1.1 Deciding where to locate your wood pellet burning fire place:

1. Do not install the pellet heater in a bedroom or room where people sleep.
2. Locate the pellet heater in a large and open room that is centrally located in the house. This will optimize heat circulation.
3. Check clearances to combustibles.

## 1.2 Floor Protection - Corina

This pellet heater requires floor protection which must be non-combustible, extending beneath the stove the full width and depth of the unit including (150mm) in front for ember protection.

AS/NZS 2918:2018 states that a 300mm forward projecting and 200mm side projecting floor protector must be used from any door opening extremity as an absolute minimum.

Due to the operating nature of the Corina pellet heater, where opening the door causes a loss of vacuum and the fire will shut down completely, meaning the likelihood of any hot embers or burning fuel escaping from the combustion chamber is extremely minimal. Therefore a 150mm forward projecting floor protector will be sufficient.

Hearth testing of the Ravelli Corina ARS 23/3128 showed that on exposed combustible surfaces front of the freestanding heater, no measure locations exceeded the temperature limits specified in AS/NZS 2918:2018

The unit can be installed in an existing fireplace or in a special compartment built to measure and covered with plasterboard; in any case the optional insert support can be requested.

If the compartment is accessible from the outside (a), position the insert with the base resting on the reference surface of the compartment, pull out the monoblock, making sure it does not tip over, and secure the base with 8 anchors to the existing support surface; if a support surface is not available (b), the height-adjustable insert support KIT, to be fixed to the floor, is available on request.

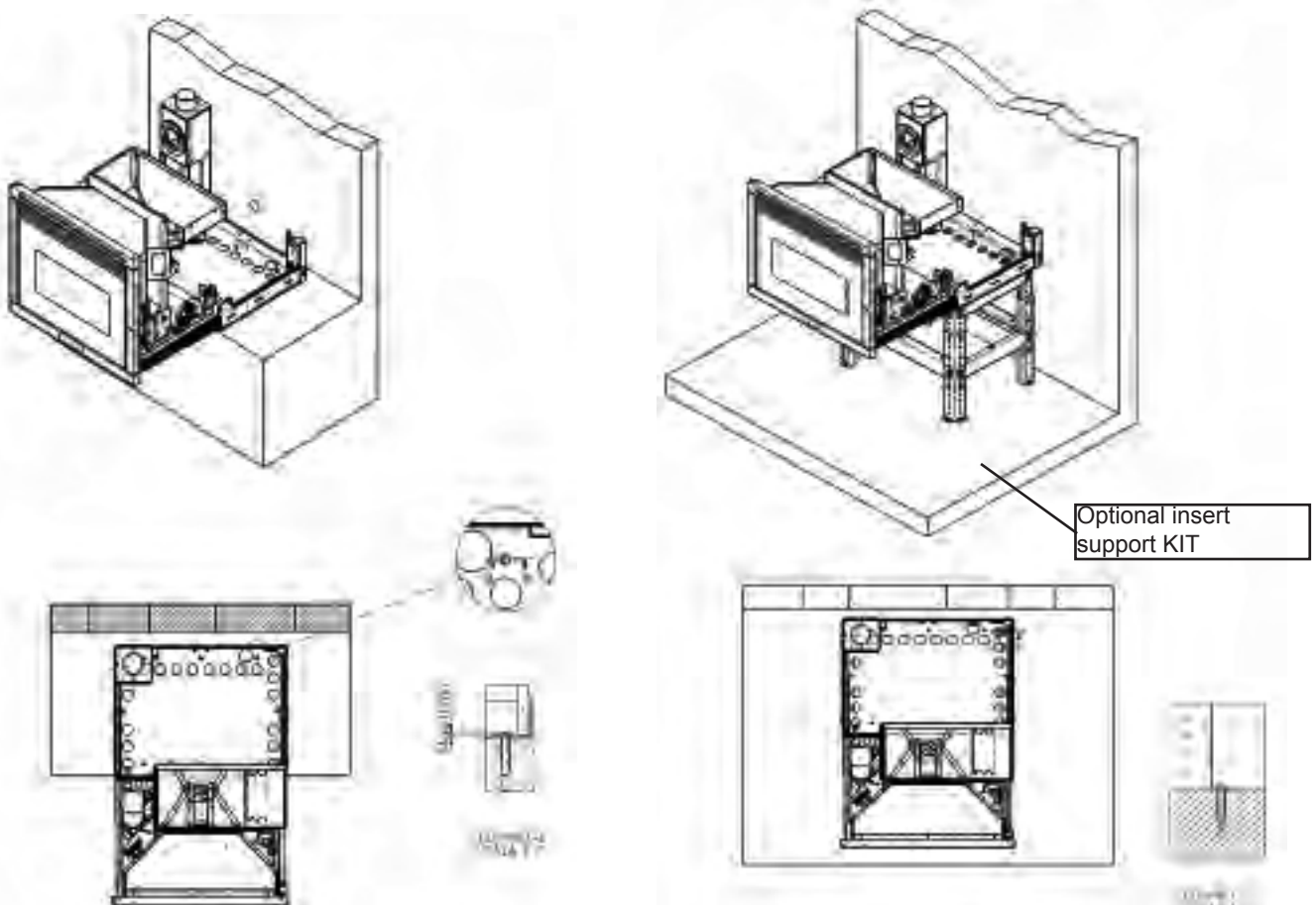

## 2. Installation

### General Information

There are two critical components when installing a Corina Insert Wood Pellet Fire: 1) Ensuring the wall cavity is the necessary size and 2) ensuring relevant clearances to combustibles are adhered to both inside and outside the cavity. Depending on the circumstances, you may also have to consider the use of a hearth, and the installation of the support frame. The Corina is typically installed into a timber cavity.

### 2.1 Dimensions – Corina Built-In Heater

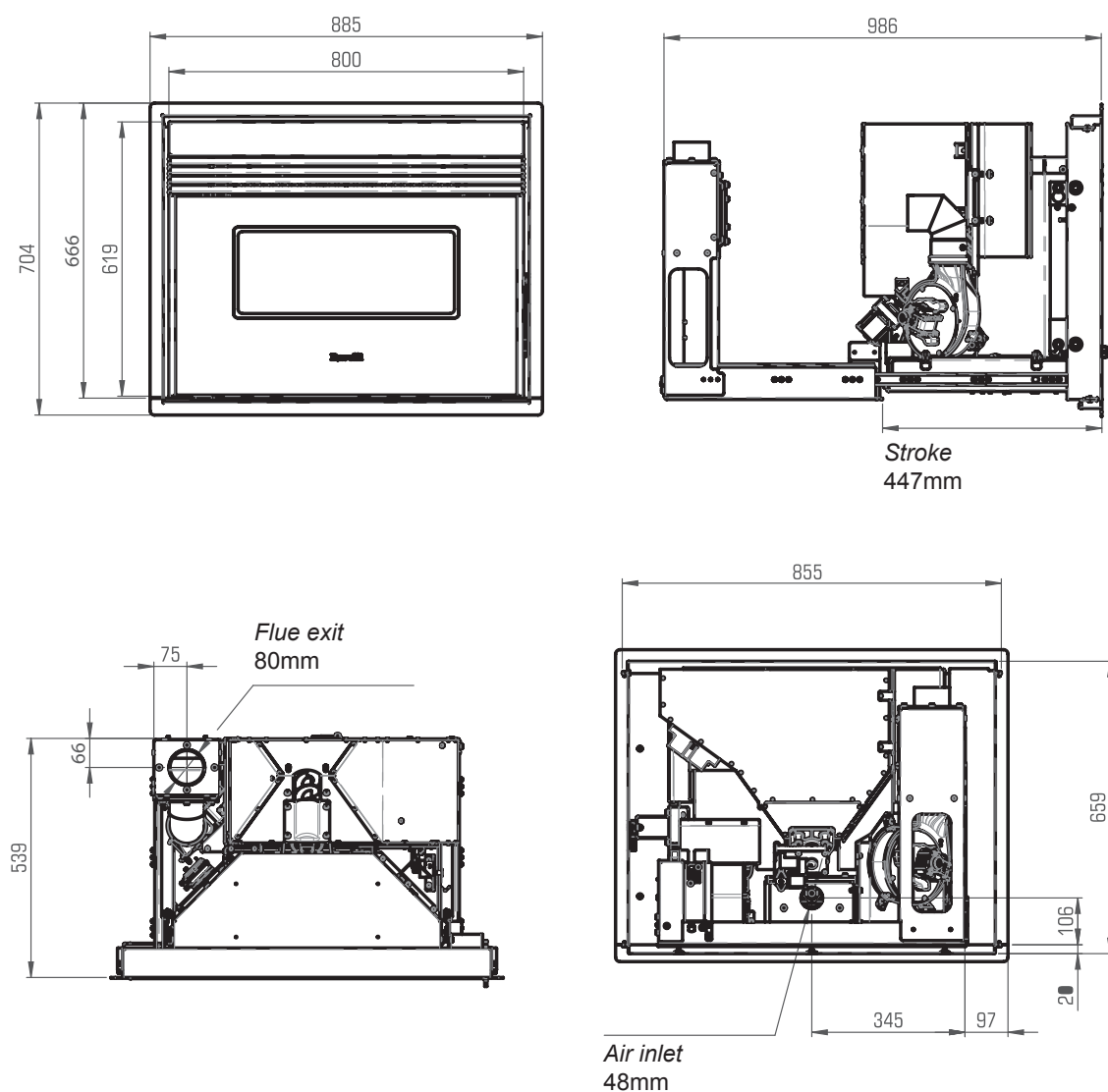

Refer to Safety Test ARS 23/3128 for all clearances to combustibles.

## 2.2 Clearances & Specifications

### Creating the Cavity - New Build

As the Corina Insert Wood Pellet Fire is typically installed in new homes, it is necessary to build a compliant cavity that will house the fire and the frame. The front fascia of the enclosure must be made of a fireproof rated board (above 80°C) such as (but not limited to) Micore, Supalux or Eterpan, and this must extend to a minimum of 165mm above the top of the fire. Within the cavity, there must be a minimum of 195mm clearance to combustibles above the fire, and a minimum 945mm gap between the top of the fire and the ceiling of the cavity. The cavity also requires a minimum of 100cm<sup>2</sup> ventilation.

#### Internal Cavity Dimensions

- (A) Width: 1020mm (min)  
 (B) Depth: 618mm (from front of wall)

Includes 100mm clearance from rear of flue spigot box.

\*\* Dependent on height at which the support frame is set.

#### Wall Opening

- (D) Width: 865mm  
 (E) Height: 655mm

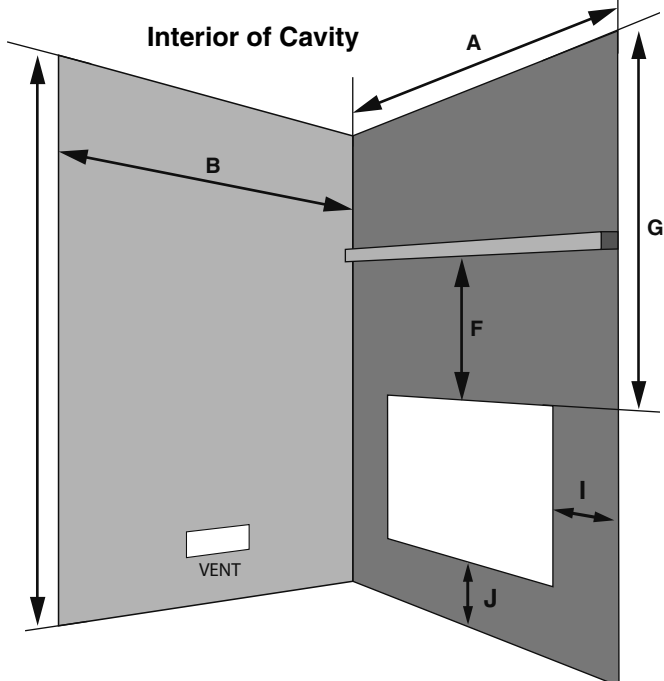

#### Cavity Clearances to Combustibles

- (F): from top of opening (inside) 195mm  
 (G): from top of opening to cavity ceiling 945mm  
 (H): from top of opening to mantle 165mm (min)  
 (I): from side of opening (inside) 78mm (min)  
 (J): from bottom of opening 200-800mm depending on height of base.

#### Additional Clearances to Combustibles

- (K): from exhaust spigot to cavity wall 100mm  
 (L): from side of fire to cavity wall 208mm  
 (M): hearth depth from front of glass 150mm  
 (N): hearth width 1200mm  
 (O): hearth depth from wall 170mm  
 (P): from side of opening to combustible 190mm

#### Exterior of Cavity

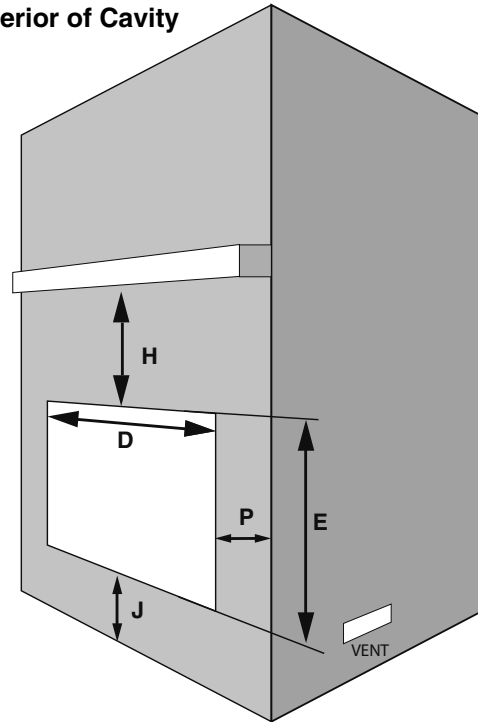

#### Surround Dimensions

Steel Fascia 1224mm (w) x 784mm (h)

The above clearance to combustibles on the flue are only applicable within the fire envelope. Clearance outside this, eg at a ceiling/wall thimble reverts to 25mm as per ARS flue test 05/1185.

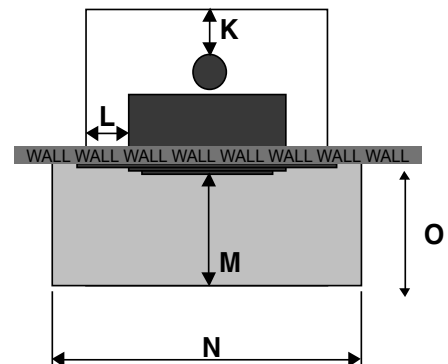

If installing a floating hearth, ensure sufficient clearance is left below the fire to allow for installation of the chosen surround.

## 2.3 Positioning of the Corina pellet fire

### Positioning

Generally, the Corina should be installed in a centrally located position within the home. When deciding where to position the appliance, you must consider the following:

1. The place of installation of the pellet fire must comply with local and national regulations. The pellet fire must be fuelled only with quality pellets manufactured to standard AS/NZS 4014.6. The pellet fire cannot operate using traditional fire wood.
2. Do not install a pellet fire in a bedroom or room where people sleep.
3. Corina has a convection fan which blows air in the direction the fire faces. For optimum performance and heat circulation, locate the pellet fire in a large and open room that is centrally located in the house.
4. The fire requires a 230 volt power supply and comes with a 2m power lead. There must be easy access to the socket so the fire can be isolated from the power if required. If the cable supplied is not long enough to reach the nearest outlet, use a suitable 3 pin extension cord. A surge protector is recommended for use with all Ravelli pellet fires.

## 2.4 Installation of the Corina Pellet Fire

Installation of the Ravelli Corina Wood Pellet Fire must be undertaken by an approved installer, who must then give the purchaser a declaration of conformity of the appliance and will assume all responsibility for the final installation and consequent correct function of the installed product.

Please read this Manual thoroughly before commencing installation, as failure to follow the instructions could cause damage to the pellet fire or property. It is also necessary for the registered installer to take into consideration all the laws and national, regional, provincial and local regulations present in the country in which the appliance has been installed. In the event of failure to respect these precautions, Pellet Fire Solutions declines all responsibility.

1. The fire must be installed on a floor with sufficient carrying capacity. If the existing building does not meet this requirement, appropriate measures must be taken (i.e. a load distribution plate).
2. Corina must be installed on a non-combustible surface. This surface must protrude a minimum of 150mm from the front of the closed pellet fire door and a minimum of 200mm from the side of the appliance. Please note that if a floating hearth is to be installed, an allowance must be made below the fire for installation of the chosen surround
3. Check clearances to combustibles (see "Creating the Cavity") to ensure sufficient space is created in the cavity, and that the position of structural elements near the proposed flue have adequate clearance.
4. Check clearance for service – as the Corina is designed to be pulled out, as long as there is front access, this should be sufficient.
5. Check there is sufficient ventilation for combustion air and this is unaffected by mechanical extraction. An external air intake may be required. (see "Creating the Cavity" for cavity ventilation requirements).
6. There must be sufficient circulation of air in the room where the pellet fire is installed. Never open the door of the pellet fire while it is functioning.
7. Check there is a suitable flue location (studs, joists, rafters etc).
8. Corina has been Safety Tested to AS/NZS 2918:2001 using the Davins manufactured flue, Test Report ARS 05/1185. Installation is not exclusive to these nominated kits, though an alternative flue should only be considered following consultation with your local council.
9. Because of the positive pressure in the flue, sealing of all 75mm stainless joints is mandatory - use high temperature Maniseal. Both inner and outer flue joints must be riveted using stainless steel rivets.

10. Before connecting the pellet fire electrically, the connection of the exhaust spigot must be completed (specifically for non-aluminium pellet fires) with the flue. (All flue joins must be sealed with Maniseal exhaust cement).
11. Seismic Restraint - please see "Seismic Restraint" to see what is required.
12. Warranty - To validate the warranty following installation, a copy of the completed Warranty/ Producer's Statement must be forwarded to Pellet Fire Solutions - info@pelletfiresolutions.co.nz

### ATTENTION

**There are two critical components when installing a Corina Insert Wood Pellet Fire:**

**1) Ensure the wall cavity is the necessary size.**

**2) Ensure relevant clearances to combustibles are adhered to both inside and outside the cavity.**

**Depending on the circumstances, you may also have to consider the use of a hearth, and the installation of a support frame.**

## 2.5 Television Clearances

If electrical equipment (eg Plasma TV, LCD TV or home theatre) is to be installed above the wood pellet fire, we recommend installing a mantle below the TV screen, or recessing the TV screen into the wall for heat protection.

The clearances shown are recommended minimums, and are to be treated as suggestions only.

The end user is responsible for checking the installation instructions and clearance requirements of their electrical appliances to ensure the appliance is suitably located in relation to the wood pellet fire. Pellet Fire Solutions and Ravelli does not guarantee that these recommended clearances will be appropriate for all electrical equipment.

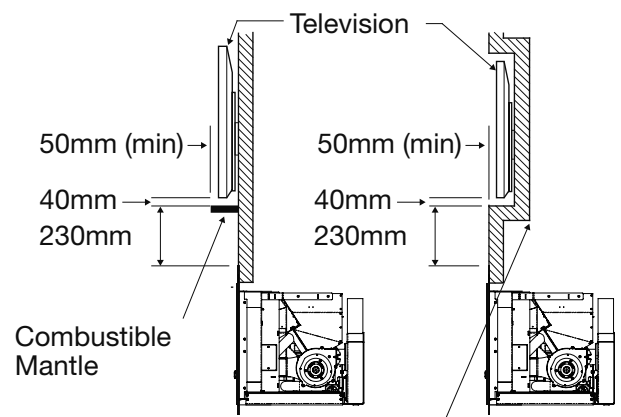

To be zero rated using eterpan etc with a 12mm air gap to comply with AS/NZS 2918 : 2018

## 2.6 Example of Cavity Design - Section View

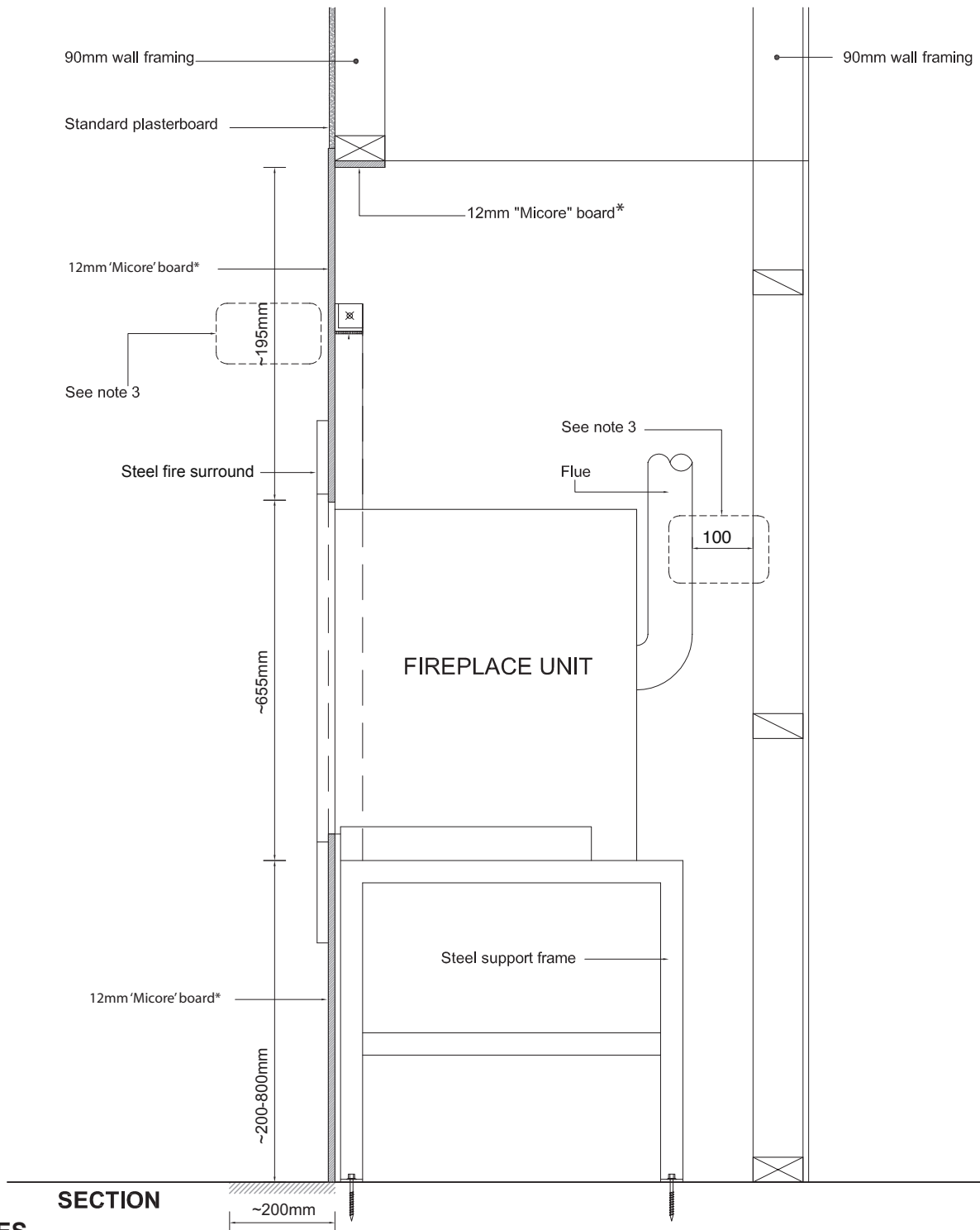

### NOTES

1. Angle section for support fixed to timber frame/floor using coach screws or 'Dynabolts' when fixing to concrete.
2. The joint for fire rated board\* and Plasterboard located over frame member must be stopped to manufacturer's instructions. Note: Wallpaper is not permitted on the front of the enclosure.
3. Comply with all minimum distance to all combustible surfaces. Any modifications to the dimensions shown to be verified by consultation with the relevant Building Consent Authority.
4. Ensure there is a minimum of 100cm<sup>2</sup> ventilation into the cavity (this does not need to be from the outside).
5. Installers must ensure adequate vermin proof measures are incorporated into the cavity construction (if applicable).

\*Ensure product being used is fireproof rated above 80°C eg Micore, Supalux, Eterpan or similar

## Example of Cavity Design - Top View

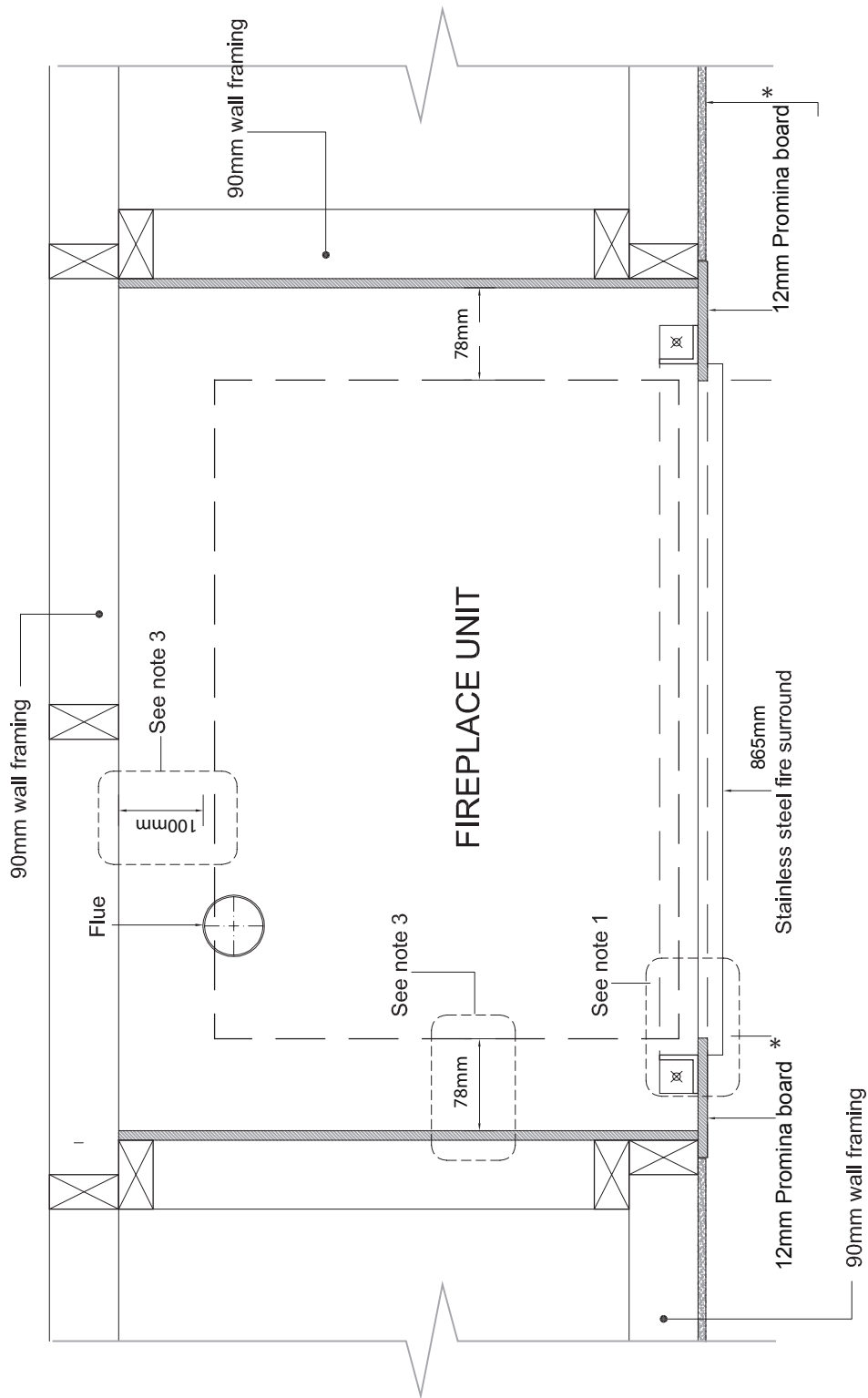

### **NOTES**

1. Angle section for support fixed to timber frame/floor using coach screws or 'Dynabolts' when fixing to concrete.
2. The joint for fire rated board\* and Plasterboard located over frame member must be stopped to manufacturer's instructions. Note: Wallpaper is not permitted on the front of the enclosure.
3. Comply with all minimum distance to all combustible surfaces. Any modifications to the dimensions shown to be verified by consultation with the relevant Building Consent Authority.
4. Ensure there is a minimum of 100cm<sup>2</sup> ventilation into the cavity (this does not need to be from the outside).
5. Installers must ensure adequate vermin proof measures are incorporated into the cavity construction (if applicable).

\*Ensure product being used is fireproof rated above 80°C eg Micore, Supalux, Eterpan or similar

## Adjusting the Support Frame (if required)

The Corina Wood Pellet Fire can be installed on the additional, adjustable support frame. The height of this frame can be set at the home-owner's desired height.

The frame is adjusted by manipulating the bolts, which are located on each of the four legs to achieve the desired height.

### 2.7 Seismic Restraint

All installation scenarios for Corina require the use of hold-down anchors (one at each corner).

#### Fixing to Concrete Floor

- Minimum M8 expansion anchors (M10 recommended) or min M8 epoxy-set anchors.
- Approved Anchors: Expansion Anchors-Ramset Dynabolt and Trubolt, Hilti HAS.
- Epoxy-set Anchors – Ramset Epcon, Ramset Chemset and Hilti HVU.

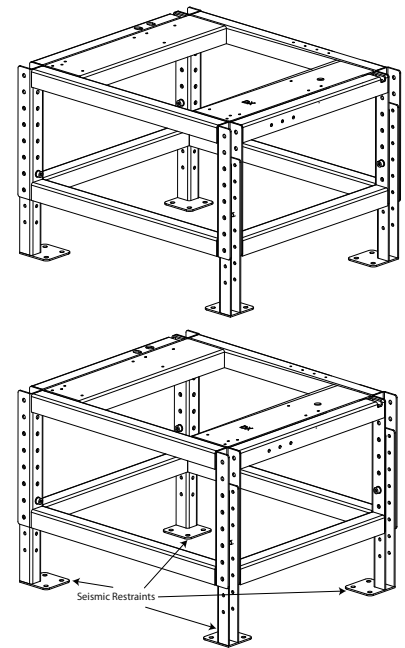

Seismic Restraint Locations

#### Fixing to Timber Flooring only

Minimum 14g x 60 screws (6.3mm diameter) or M10 X 90 coach-screws. Thickness of flooring must be 20mm minimum. The flooring shall be fixed to the nearest joist with two 8g x 40 screws per hold down anchor.

#### Fixing to Timber Floor Framing

Minimum 14g x 60 screws (6.3 diameter) or M10 x 90 coach-screws. These shall be fixed a minimum of 40mm into the centre-line of the existing floor joists. If screws cannot be installed directly into an existing floor joist, slid blocking between joists (min size 90x45) shall be provided.

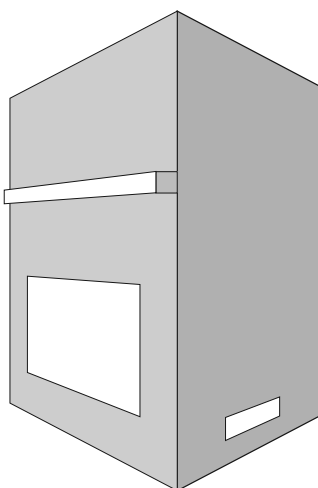

### Ventilation

The Corina wood pellet fire requires fresh air to function properly. Without sufficient ventilation, the combustion process can be compromised, resulting in issues such as a lazy flame, smoke, incomplete fuel combustion, wasted fuel, excessive ash build-up and clinker.

To ensure the wood pellet fire does not struggle to access combustion air, ventilation (air vents) should be situated as close to the fire as practicable, within the parameters of the cavity.



## 2.8 Examples of installation of a pellet insert

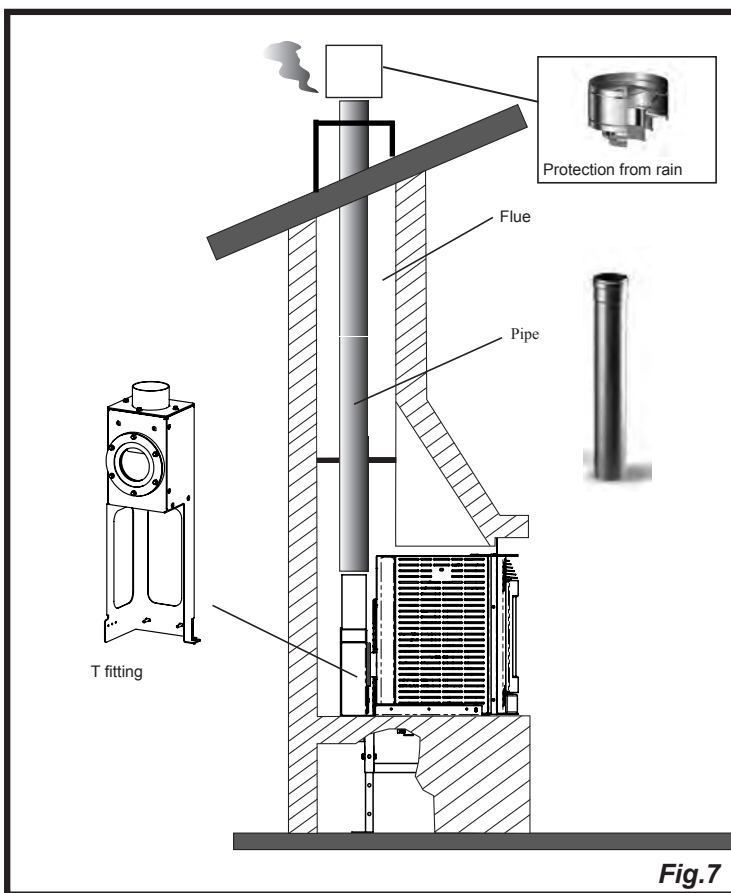

In this type of installation we can notice that the fitting was used to enable connecting the insert to the chimney (so-called "bayonet" mount).

For safety reasons and to ensure proper operation, we recommend you fit pipes into the chimney. (Fig.7)

It is recommended to perfectly match the insert with the fitting, to prevent leaks of smoke during the work phase.

View of T fit

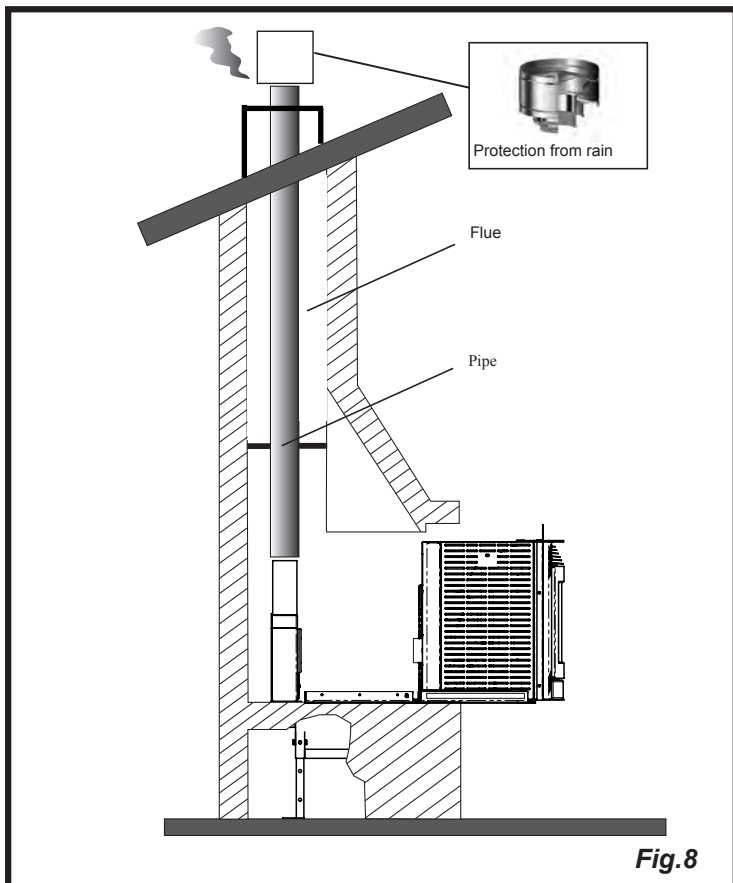
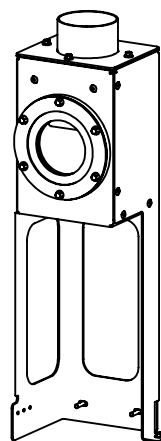

Here you can see the possibility to slide the insert; this operation can only be performed with the stove turned off for loading pellets or during regular checks. (Fig.8)



IT IS STRICTLY FORBIDDEN TO REMOVE THE STOVE DURING THE WORK PHASES; THE FUME MAY DISPERSE INTO THE

## 2.9 Electrical Connection

### **! IMPORTANT**

The connections must be set up by a technician that is qualified and/or authorised by the Manufacturer.

#### **Electrical connection**

The insert is equipped with a three-pole cable (Fig.2), for a correct installation it is necessary to provide the dedicated electrical connection under magneto-thermic (Fig.1) of adequate size according to the absorption of the generator in order to guarantee the maximum safety of the installation.



**Fig.1**



**Fig.2**

#### **Testing and commissioning**

Stove start-up must be preceded by testing, which includes an operational check of the following elements:

- connection to the smoke evacuation system;
- checking that all materials used to build the smoke duct, chimney and chimney pot are regulation and suitable for use.

The testing is positive only when all operational phases have been completed without any anomaly being detected.

## 2.10 Circuit Board Layout

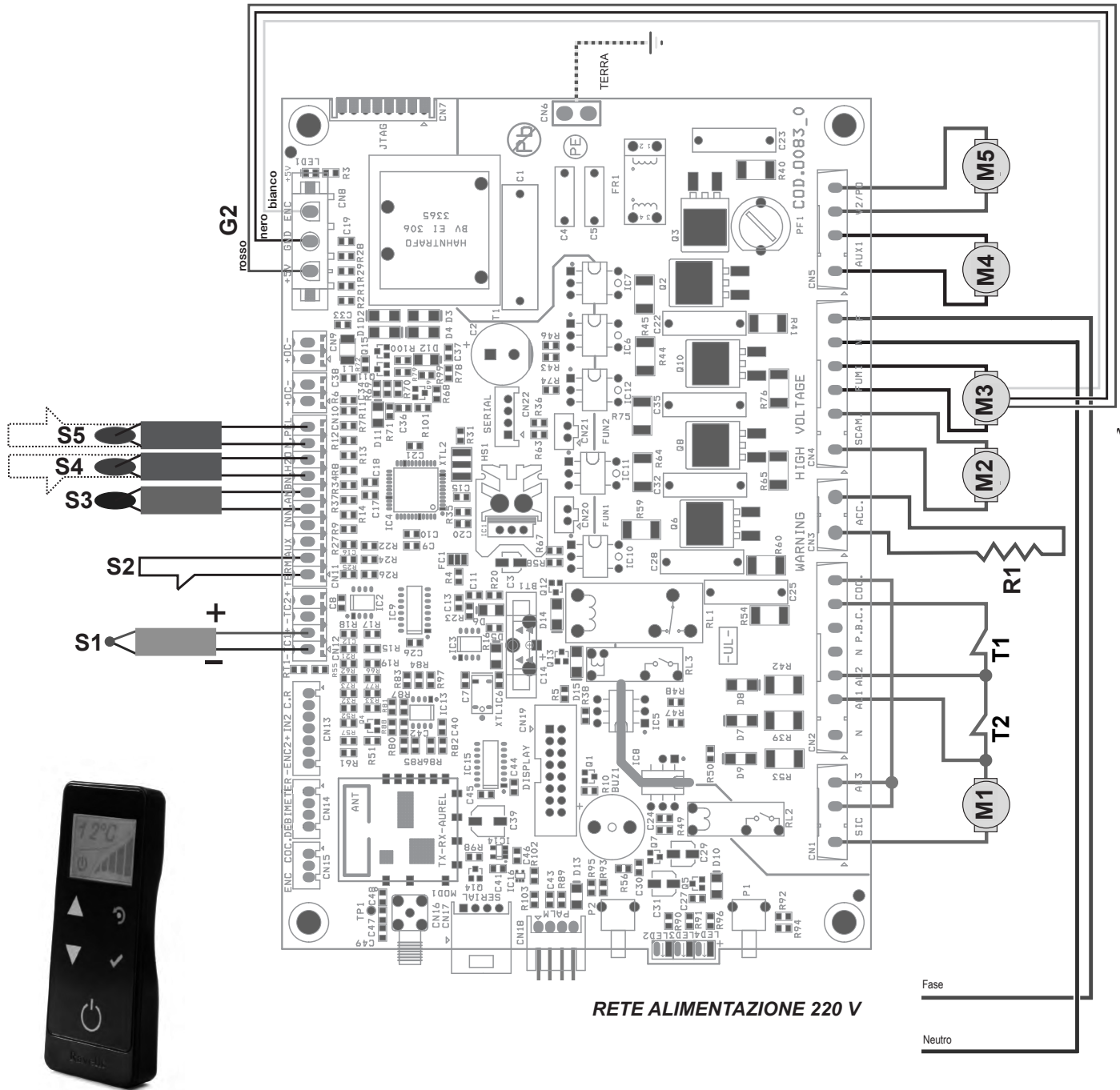

### LEGEND:

#### Safety devices

- T1 - Vacuum switch
- T2 - Pellet safety

#### Motors

- M1 - Auger gear motor
- M2 - Room fan
- M3 - Fume exhaust system

#### Resistance

- R1 - 250watt heater

#### Probes

- S1 - Fume probe (J)
- S2 - External thermostat
- S3 - Room probe
- S4 - Rear or Right Probe/EXT.T.
- S5 - Left Probe/EXT.T.

#### General

- G2 - Extractor revolution reading encoder
- G3 - RADIO Touch handheld remote control

## 58.

## Ravelli Sofia and Corina – new home non-Chimney installation

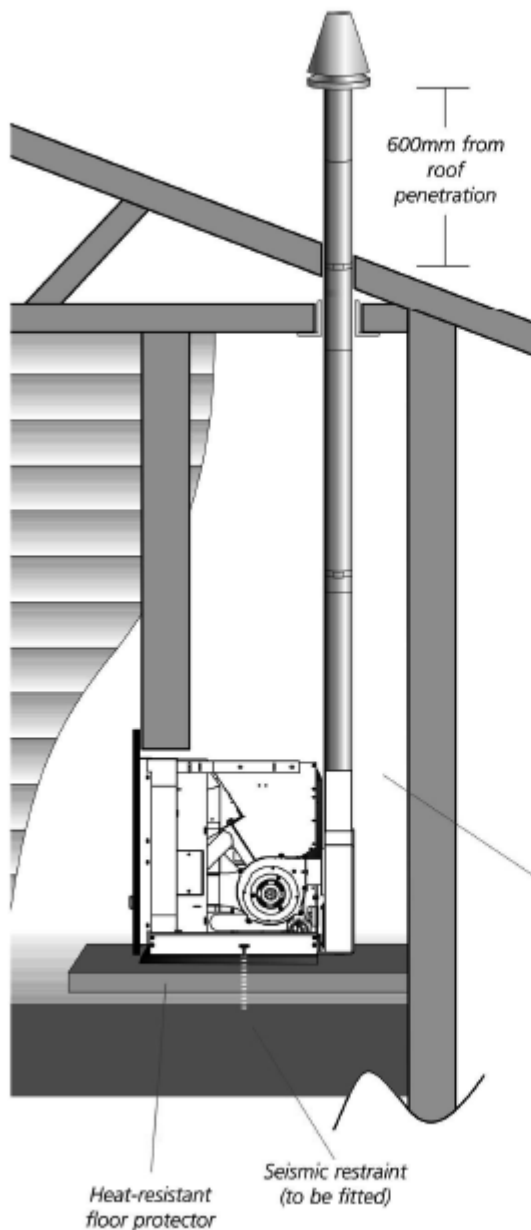

This flue kit may be used in new or existing timber chimneys. The overall height of the flue is 3.6m. Kit is supplied in a carton.

Each 58 Built-in-Heater Flue kit (non-Chimney installation) contains:-

Part No	Description	Quantity
1	Galvanized Outer Flue Liner 100mmØ x 900mm long	4
2	Stainless Steel inner Liner 75mmØ x 900mm	4
5	Inner/Outer Flue Liner Spacer	2
6c	Ceiling Thimble 107mmØ Hole	1
9	Rain Cap 100mmØ	1
46	Velocity Cone	1
73.	76 - 80mm Ravelli Adaptor	1
702	Support Angle 950mmLong x 40mm x 40mm	2

**Note:** The Davin 58 Built-in-Heater Flue Kit for Sofia and Corina (non-Chimney) complies with AS/NZS 2918:2001 as per Applied Research Test Report 05/1185, dated 15th September 2005. All fires must be installed by a qualified installer as per the manufacturer's instructions.

## 58.1

## Ravelli Sofia and Corina – new home (Chimney installation)

This flue kit may be used in new or existing timber chimneys. The overall height of the flue is 3.6m. Kit is supplied in a carton.

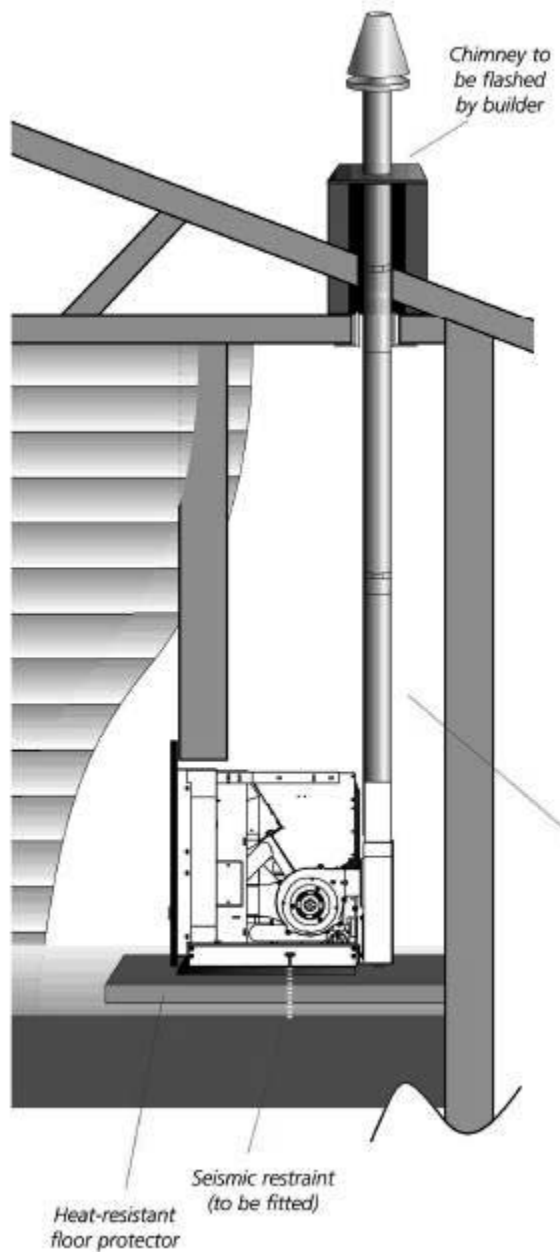

Each 58 Built-in-Heater Flue kit  
(Chimney installation) contains:-

Part No	Description	Quantity
1	Galvanized Outer Flue Liner 100mm $\varnothing$ x 900mm long	4
2	Stainless Steel inner Liner 75mm $\varnothing$ x 900mm	4
5	Inner/Outer Flue Liner Spacer	2
6c	Ceiling Thimble 107mm $\varnothing$ Hole	1
9	Rain Cap 100mm $\varnothing$	1
10	Telescopic offset 75mm $\varnothing$	1
11	Telescopic offset 100mm $\varnothing$	1
46	Velocity Cone	1
73.	76 - 80mm Ravelli Adaptor	1
702	Support Angle 950mmLong x 40mm x 40mm	2

25mm minimum clearance if lined.  
75mm minimum clearance if unlined

**Note:** The Davin 58.1 Built-in-Heater Flue Kit for Sofia and Corina (Chimney) complies with AS/NZS 2918:2001 as per Applied Research Test Report 05/1185, dated 15th September 2005. All fires must be installed by a qualified installer as per the manufacturer's instructions.

### 3. Installation Data Sheet

Name of Owner:

\_\_\_\_\_

Address:

\_\_\_\_\_

\_\_\_\_\_

\_\_\_\_\_

\_\_\_\_\_

Phone:

\_\_\_\_\_

Name of Dealer:

\_\_\_\_\_

Address:

\_\_\_\_\_

\_\_\_\_\_

\_\_\_\_\_

\_\_\_\_\_

Phone:

\_\_\_\_\_

Model: \_\_\_\_\_

Serial Number: \_\_\_\_\_

Date of Purchase: \_\_\_\_\_ (dd/mm/yy)

Date of Installation: \_\_\_\_\_ (dd/mm/yy)

Magnehelic at Install: \_\_\_\_\_

Installer's Signature:

\_\_\_\_\_

Name of Installer:

\_\_\_\_\_

Address:

\_\_\_\_\_

\_\_\_\_\_

\_\_\_\_\_

\_\_\_\_\_

Phone:

\_\_\_\_\_

**WARRANTY:** If you have concerns with your unit please contact the dealer where you purchased the stove.

**4. Maintenance Record**

DATE	WORK CARRIED OUT	SIGNATURE



## PRODUCER REGISTRATION FORM

This form must be completed and returned for every installation to qualify for warranty.

Post to: P O Box 11-245, Sockburn, Christchurch

Email to: [info@pelletfiresolutions.co.nz](mailto:info@pelletfiresolutions.co.nz)

### **Customer Details:**

Customer Name: \_\_\_\_\_

Postal Address: \_\_\_\_\_

Installation Address: \_\_\_\_\_

Phone Number	Cell Phone	Email Address
_____	_____	_____

**Declaration by Owner:** I hereby certify the above particulars are true and correct. My Pellet Fire Technician has demonstrated to me the correct operation of my Pellet Fire.

I understand that warranty conditions require an authorised Pellet Fire Solutions Installer to complete the installation

Signed: \_\_\_\_\_ Date: \_\_\_\_\_

### **Installation Details:**

Pellet Fire Model & Serial Number: \_\_\_\_\_

Installation Date: \_\_\_\_\_

Freestanding Flue Kit: Internal  External Standard

Fireplace Insert Flue Kit: Insert  BIH

Installer Details: \_\_\_\_\_

Installers Name: \_\_\_\_\_ Phone Number: \_\_\_\_\_

Passed Inspection Yes/No (if no, why) \_\_\_\_\_

Declaration by Approved Technician: I \_\_\_\_\_ hereby certify that the above appliance has been installed and commissioned in compliance with Manufacturers Installation requirements and appropriate New Zealand Standards/Local Council requirements.

Signed: \_\_\_\_\_ Date: \_\_\_\_\_