

Ravelli Corina Insert Wood Pellet Fire



Ravelli Corina Insert Wood Pellet Fire Installation Specifications

Safety testing of the Ravelli Corina Insert Wood Pellet Burning Heater to AS/NZS 2918:2018 Appendix B ARS 23/3128

Flue Kit Testing to AS/NZS 2918:2001 App F: ARS 05/1185

Emissions CS17 - 0018426 - 01

1. Installation

General Information

There are two critical components when installing a Corina Insert Wood Pellet Fire: 1) Ensuring the wall cavity is the necessary size and 2) ensuring relevant clearances to combustibles are adhered to both inside and outside the cavity. Depending on the circumstances, you may also have to consider the use of a hearth, and the installation of the support frame. The Corina is typically installed into a timber cavity.

1.1 Dimensions – Corina Built-In Heater

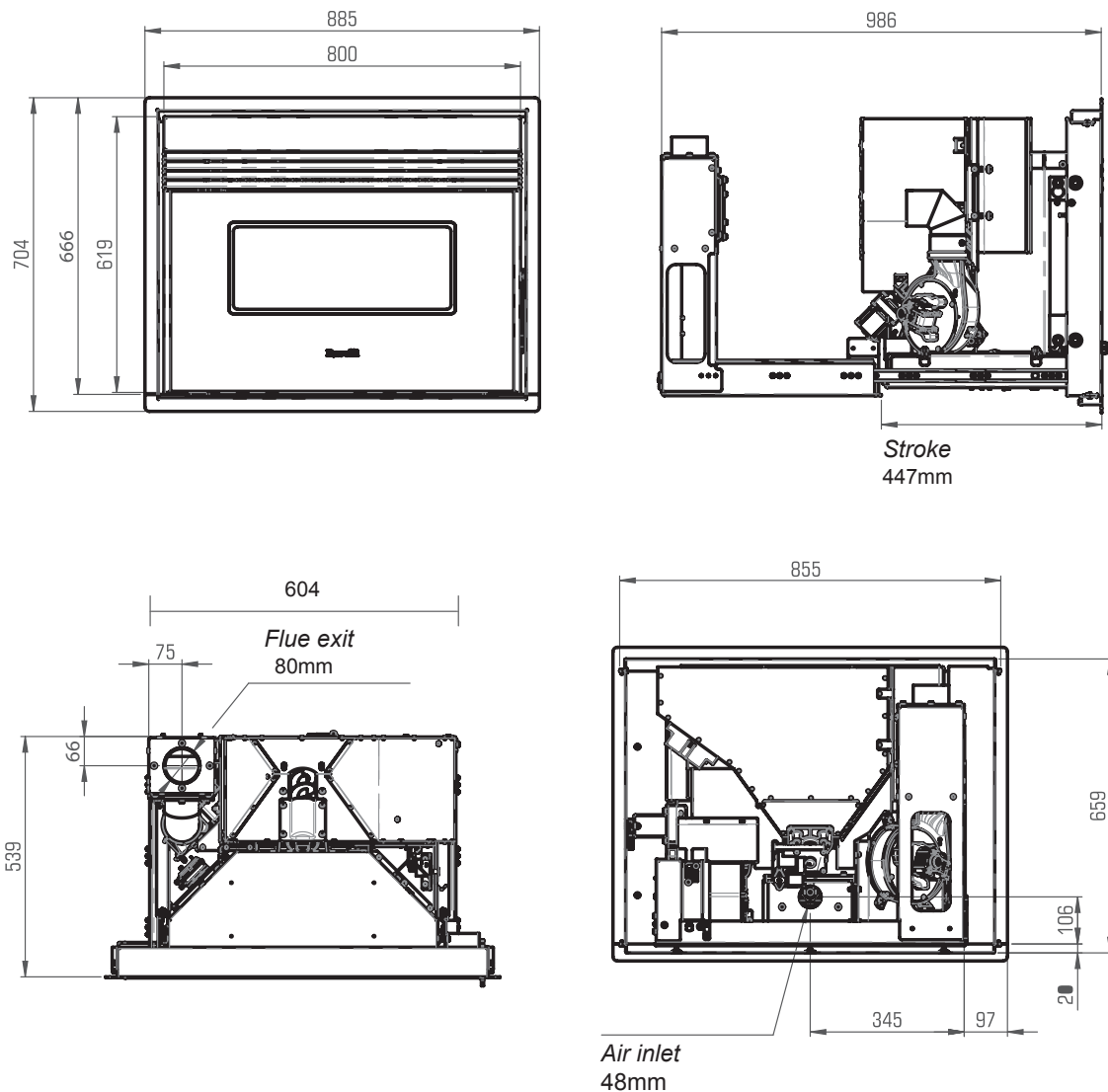

Refer to Safety Test ARS 23/3128 for all clearances to combustibles.

1.2 Clearances & Specifications

Creating the Cavity - New Build

As the Corina Insert Wood Pellet Fire is typically installed in new homes, it is necessary to build a compliant cavity that will house the fire and the frame. The front facia of the enclosure must be made of a fireproof rated board (above 80°C) such as (but not limited to) Micore, Supalux or Eterpan, and this must extend to a minimum of 165mm above the top of the fire. Within the cavity, there must be a minimum of 195mm clearance to combustibles above the fire, and a minimum 945mm gap between the top of the fire and the ceiling of the cavity. The cavity also requires a minimum of 2 x 100cm² ventilation.

Internal Cavity Dimensions

- (A) Width: 1020mm (min)
 (B) Depth: 618mm (from front of wall)

Includes 100mm clearance from rear of flue spigot box.

Wall Opening

- (D) Width: 865mm
 (E) Height: 655mm

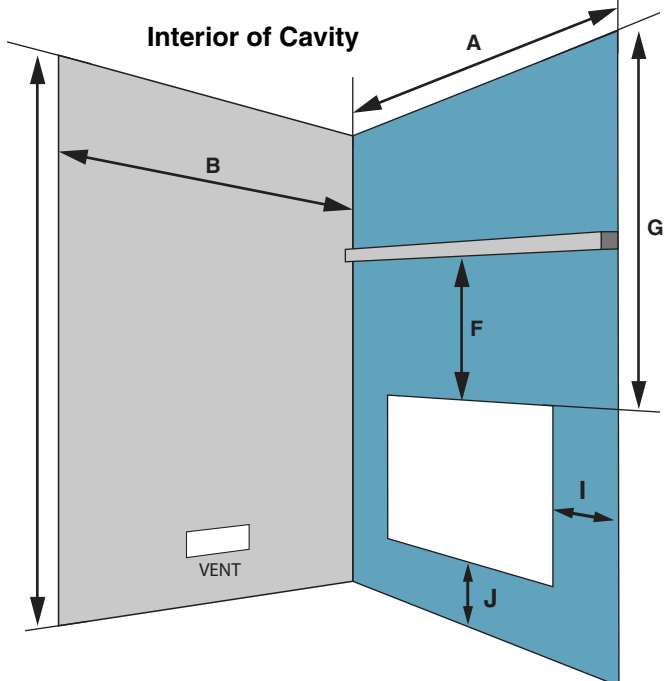

Cavity Clearances to Combustibles

- (F): from top of opening (inside) 195mm
 (G): from top of opening to cavity ceiling 945mm
 (H): from top of opening to mantle 165mm (min)
 (I): from side of opening (inside) 78mm (min)
 (J): from bottom of opening 200-800mm depending on height of base.

Additional Clearances to Combustibles

- (K): from exhaust spigot to cavity wall 100mm
 (L): from side of fire to cavity wall 208mm
 (M): hearth depth from front of glass 150mm
 (N): hearth width 1200mm
 (O): hearth depth from wall 170mm
 (P): from side of opening to combustible 190mm

Exterior of Cavity

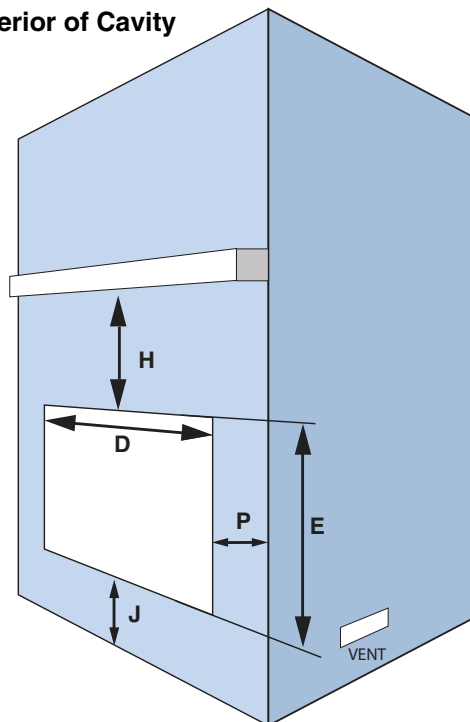

Surround Dimensions

Steel Fascia 1224mm (w) x 784mm (h)

The above clearance to combustibles on the flue are only applicable within the fire envelope. Clearance outside this, eg at a ceiling/wall thimble reverts to 25mm as per ARS flue test 05/1185.

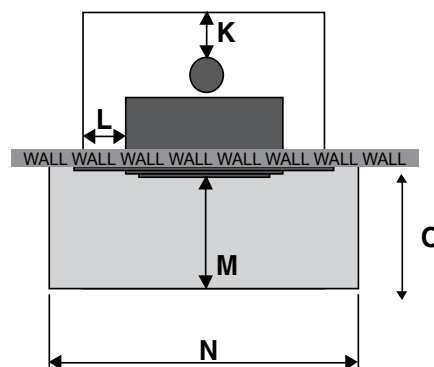

If installing a floating hearth, ensure sufficient clearance is left below the fire to allow for installation of the chosen surround.

1.3 Positioning of the Corina pellet fire

Positioning

Generally, the Corina should be installed in a centrally located position within the home. When deciding where to position the appliance, you must consider the following:

1. The place of installation of the pellet fire must comply with local and national regulations. The pellet fire must be fuelled only with quality pellets manufactured to standard AS/NZS 4014.6. The pellet fire cannot operate using traditional fire wood.
2. Do not install a pellet fire in a bedroom or room where people sleep.
3. Corina has a convection fan which blows air in the direction the fire faces. For optimum performance and heat circulation, locate the pellet fire in a large and open room that is centrally located in the house.
4. The fire requires a 230 volt power supply and comes with a 2m power lead. There must be easy access to the socket so the fire can be isolated from the power if required. A surge protector is recommended for use with all Ravelli pellet fires.

1.4 Installation of the Corina Pellet Fire

Installation of the Ravelli Corina Wood Pellet Fire must be undertaken by an approved installer, who must then give the purchaser a declaration of conformity of the appliance and will assume all responsibility for the final installation and consequent correct function of the installed product.

Please read this Manual thoroughly before commencing installation, as failure to follow the instructions could cause damage to the pellet fire or property. It is also necessary for the registered installer to take into consideration all the laws and national, regional, provincial and local regulations present in the country in which the appliance has been installed. In the event of failure to respect these precautions, Pellet Fire Solutions declines all responsibility.

Installing

1. First thing to do is remove the "Corina" Pellet Fire off the lower base by removing the 4 nuts.
2. Place the lower base onto the already constructed timber base, which needs to be lined with 10mm fireproof board.
3. Set the front edge of the lower base 20mm back from the finished front face of the enclosure.
4. Fix the lower base to the timber joists constructing the base of the cavity (anchor bolts not supplied).
5. With the lower base fitted, the flue should now be able to be installed.
6. Electrical connection can now be completed.
7. Once flue and electrical connection are completed, the "Corina" Pellet Fire can be placed on the lower base.
8. Surround and pellet loading chute (if being fitted) can then be fitted and commissioning of "Corina" Pellet Fire can be undertaken.

Notes to Consider

1. The fire must be installed on a floor with sufficient carrying capacity. If the existing building does not meet this requirement, appropriate measures must be taken (i.e. a load distribution plate).
2. Corina must be installed on a non-combustible surface. This surface must protrude a minimum of 150mm from the front of the closed pellet fire door and a minimum of 200mm from the side of the appliance. Please note that if a floating hearth is to be installed, an allowance must be made below the fire for installation of the chosen surround
3. Check clearances to combustibles (see “Creating the Cavity”) to ensure sufficient space is created in the cavity, and that the position of structural elements near the proposed flue have adequate clearance.
4. Check clearance for service – as the Corina is designed to be pulled out, as long as there is front access, this should be sufficient.
5. Check there is sufficient ventilation for combustion air and this is unaffected by mechanical extraction. An external air intake may be required. (see “Creating the Cavity” for cavity ventilation requirements).
6. There must be sufficient circulation of air in the room where the pellet fire is installed. Never open the door of the pellet fire while it is functioning.
7. Check there is a suitable flue location (studs, joists, rafters etc).
8. Corina has been Safety Tested to AS/NZS 2918:2001 using the Davins manufactured flue, Test Report ARS 05/1185. Installation is not exclusive to these nominated kits, though an alternative flue should only be considered following consultation with your local council.
9. Because of the positive pressure in the flue, sealing of all 75mm stainless joints is mandatory - use high temperature Maniseal. Both inner and outer flue joints must be riveted using stainless steel rivets.
10. Before connecting the pellet fire electrically. the connection of the exhaust spigot must be completed (specifically for non-aluminium pellet fires) with the flue. (All flue joins must be sealed with Maniseal exhaust cement).
11. Seismic Restraint - please see “Seismic Restraint” to see what is required.
12. Warranty - To validate the warranty following installation, a copy of the completed Warranty/ Producer’s Statement must be forwarded to Pellet Fire Solutions - info@pelletfiresolutions.co.nz

ATTENTION

There are two critical components when installing a Corina Insert Wood Pellet Fire:

1) Ensure the wall cavity is the necessary size.

2) Ensure relevant clearances to combustibles are adhered to both inside and outside the cavity.

Depending on the circumstances, you may also have to consider the use of a hearth, and the installation of a support frame.

1.5 Television Clearances

If electrical equipment (eg Plasma TV, LCD TV or home theatre)(eg Plasma is to be installed above the wood pellet fire, we recommend installing a mantle below the TV screen, or recessing the TV screen into the wall for heat protection.

The clearances shown are recommended minimums, and are to be treated as suggestions only.

The end user is responsible for checking the installation instructions and clearance requirements of their electrical appliances to ensure the appliance is suitably located in relation to the wood pellet fire. Pellet Fire Solutions and Ravelli does not guarantee that these recommended clearances will be appropriate for all electrical equipment.

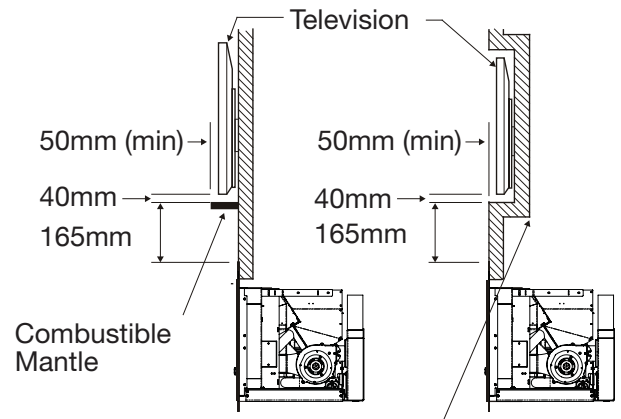

To be zero rated using eterpan etc with a 12mm air gap to comply with AS/NZS 2918 : 2018

1.6 Seismic Restraint

All installation scenarios for Corina require the use of hold-down anchors (one at each corner).

Fixing to Concrete Floor

- Minimum M8 expansion anchors (M10 recommended) or min M8 epoxy- set anchors.
- Approved Anchors: Expansion Anchors-Ramset Dynabolt and Trubolt, Hilti HAS.
- Epoxy-set Anchors – Ramset Epcon, Ramset Chemset and Hilti HVU.

Fixing to Timber Flooring only

Minimum 14g x 60 screws (6.3mm diameter) or M10 X 90 coach-screws. Thickness of flooring must be 20mm minimum. The flooring shall be fixed to the nearest joist with two 8g x 40 screws per hold down anchor.

Fixing to Timber Floor Framing

Minimum 14g x 60 screws (6.3 diameter) or M10 x 90 coach-screws. These shall be fixed a minimum of 40mm into the centre-line of the existing floor joists. If screws cannot be installed directly into an existing floor joist, slid blocking between joists (min size 90x45) shall be provided.

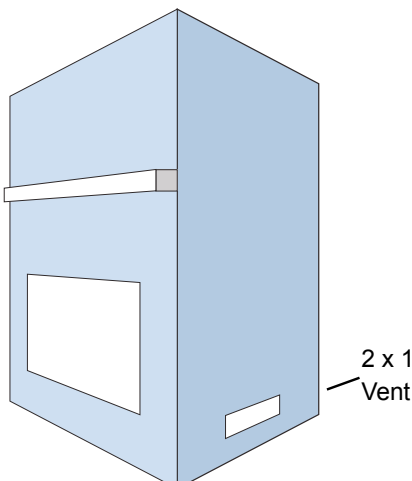

Ventilation

The Corina wood pellet fire requires fresh air to function properly. Without sufficient ventilation, the combustion process can be compromised, resulting in issues such as a lazy flame, smoke, incomplete fuel combustion, wasted fuel, excessive ash build-up and clinker.

To ensure the wood pellet fire does not struggle to access combustion air, ventilation (air vents) should be situated as close to the fire as practicable, within the parameters of the cavity.

1.7 Example of Cavity Design - Section View

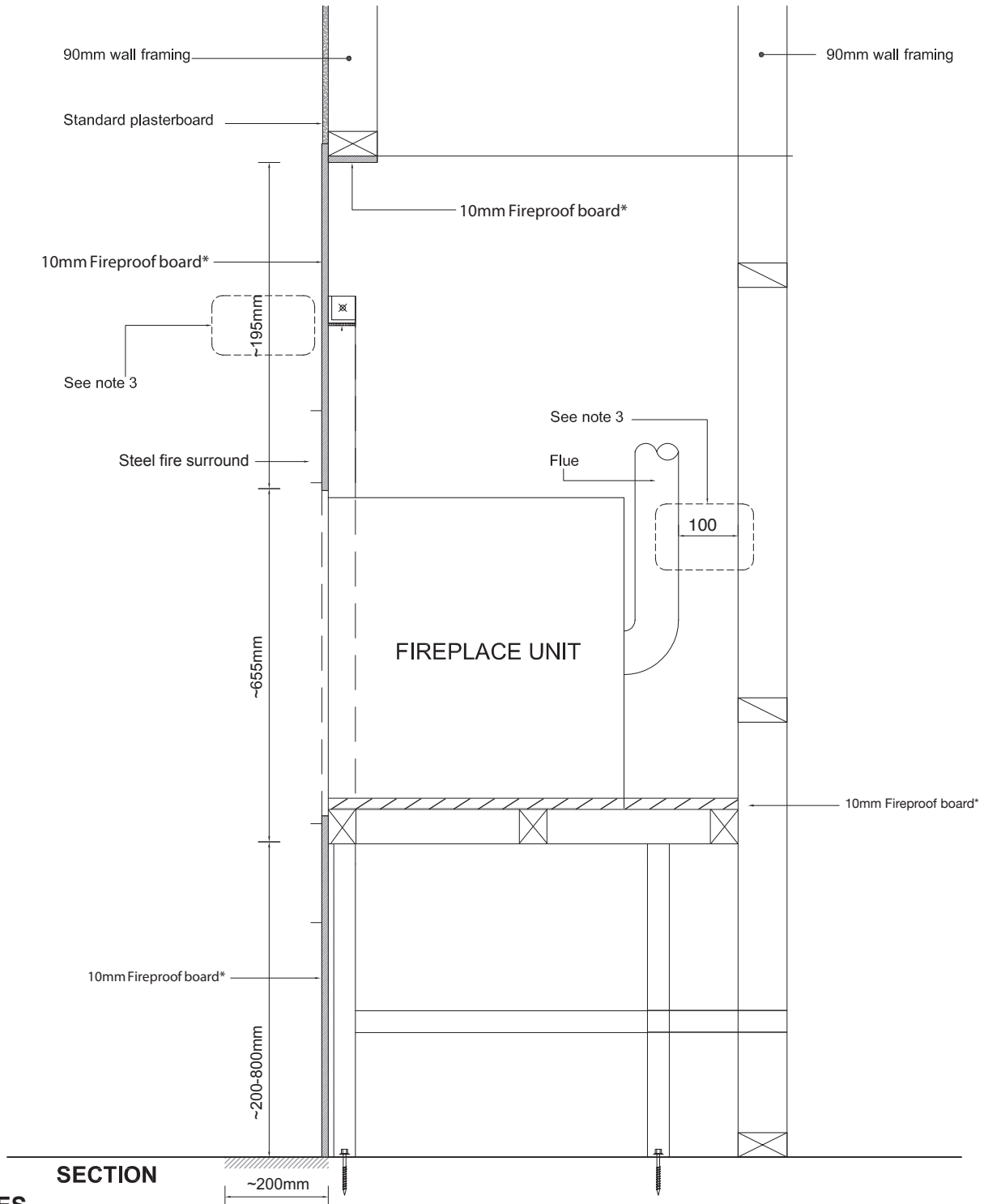

NOTES

1. Angle section for support fixed to timber frame/floor using coach screws or 'Dynabolts' when fixing to concrete.
2. The joint for fire rated board* and Plasterboard located over frame member must be stopped to manufacturer's instructions. Note: Wallpaper is not permitted on the front of the enclosure.
3. Comply with all minimum distance to all combustible surfaces. Any modifications to the dimensions shown to be verified by consultation with the relevant Building Consent Authority.
4. Ensure there is a minimum of 2 x 100cm² ventilation into the cavity (this does not need to be from the outside).
5. Installers must ensure adequate vermin proof measures are incorporated into the cavity construction (if applicable).

* Ensure product being used is fireproof rated above 80°C eg Micore, Supalux, Eterpan or similar

Example of Cavity Design - Top View

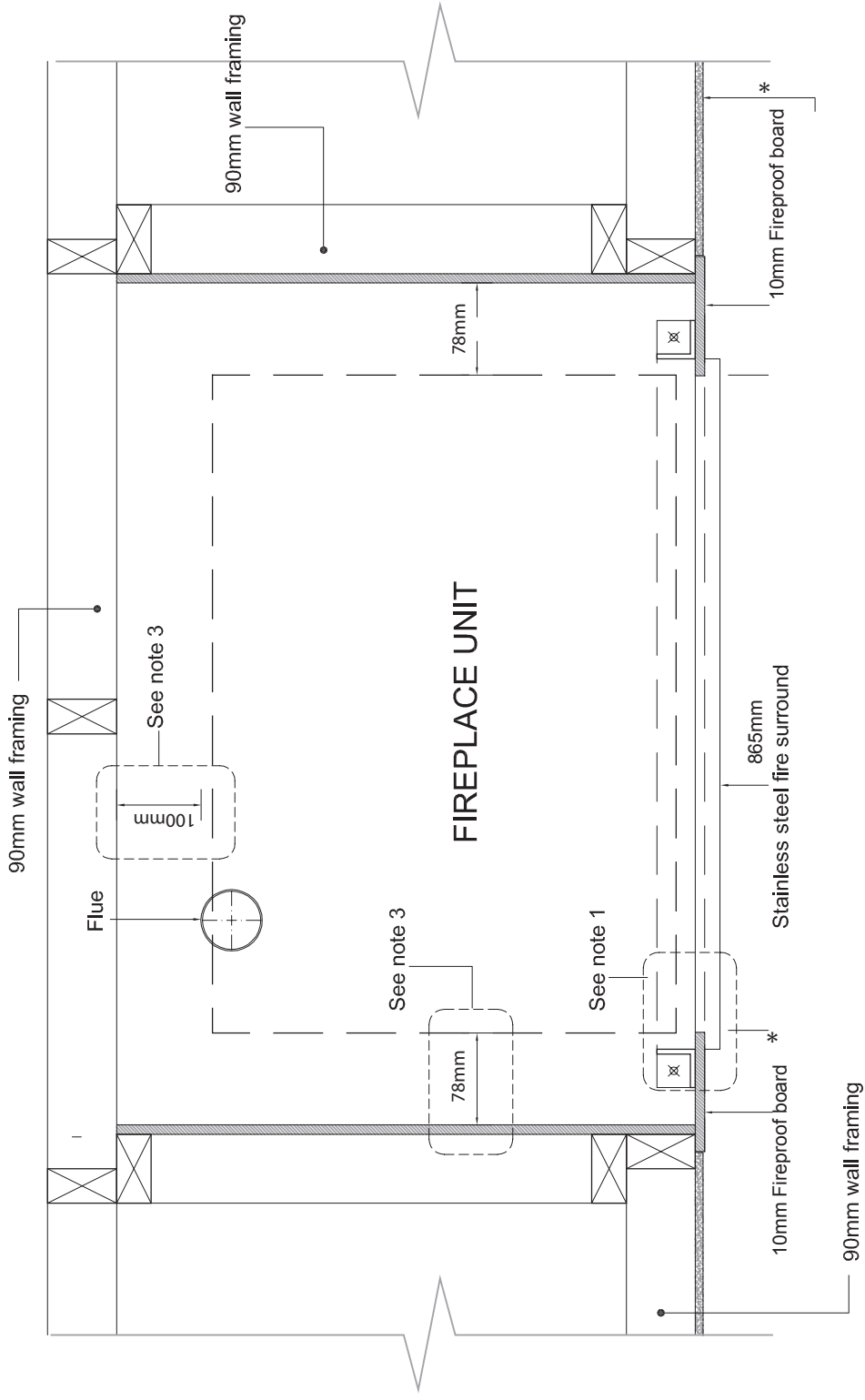

NOTES

1. Angle section for support fixed to timber frame/floor using coach screws or 'Dynabolts' when fixing to concrete.
2. The joint for fire rated board* and Plasterboard located over frame member must be stopped to manufacturer's instructions. Note: Wallpaper is not permitted on the front of the enclosure.
3. Comply with all minimum distance to all combustible surfaces. Any modifications to the dimensions shown to be verified by consultation with the relevant Building Consent Authority.
4. Ensure there is a minimum of 2 x 100cm² ventilation into the cavity (this does not need to be from the outside).
5. Installers must ensure adequate vermin proof measures are incorporated into the cavity construction (if applicable).

*Ensure product being used is fireproof rated above 80°C eg Micore, Supalux, Eterpan or similar