

Sara Wood Pellet Fire Owner's & Installation Manual

PLEASE READ THIS ENTIRE MANUAL BEFORE INSTALLATION AND USE OF THIS WOOD PELLET FIRE.
FAILURE TO FOLLOW THESE INSTRUCTIONS COULD RESULT IN PROPERTY DAMAGE, BODILY INJURY, OR
EVEN DEATH.

Contact your local building or fire official about restrictions and installation inspection requirements in your area.

ATTENTION

If you are a not a registered Pellet Fire Solutions wood pellet fire installer, and do not have legitimate access to the necessary passwords to install and program the Sara Wood Pellet fire, you MUST NOT install or attempt to install this fire.

The Sara Wood Pellet fire requires technical programming and individualised air pressure adjustments to ensure it will operate safely and efficiently, and to avoid possible damage to the fire or the home.

Installation of the Sara Wood Pellet fire by a non-registered installer will void the warranty, and may result in your local authority refusing to approve the necessaries permits.

If you require a registered Pellet Fire Solutions installer, please contact us directly on info@pelletfiresolutions.co.nz.



Owners Section - Table of Contents

1. Contents

Introduction	2	Maintenance and Cleaning	13
Specifications	2	Burn Pot Liner (daily).....	13
Safety Warnings & Maintenance Recommendations	3	Heat Exchanger Tubes (daily)	14
Pellet Quality	3	Firebox, Flame Trap, Burn Pot Holder and FIREX Lining (3-5 days).....	14
Flammable Liquids	3	Ash Pan (3-5 days).....	15
Cleaning the fire pot before and after each lighting	3	Door Glass (3-5 days or as required)	15
Clinkering	4	Seal & Gaskets (monthly).....	15
What are Wood Pellets?	4	Pellet Hopper (monthly).....	15
Maintenance and Cleaning	4	Fresh Air Intake (yearly or as required)	15
Components of the Fire.....	4	Flue System (yearly)	15
Before you begin	5	Blower Mechanisms (yearly)	16
Cleaning the surfaces.....	5	Post season clean-up.....	16
Responsibility	5	Cleaning the surfaces.....	16
Spare Parts	5	Maintenance Record	17
Operating your Pellet Fire	5	Warranty Information	18
Starting your Pellet Fire for the first time	5	Warranty Process Overview	18
Filling the Pellet Hopper	6	Warranty Cover	19
Understanding the Remote Control.....	7	Warranty Exclusions, limitations & clarification.....	21
Synchronising the Remote Control with the Pellet Fire.....	7	Proof of Purchase/Warranty	23
Switching on the Stove.....	7		
Operating Instructions	8		
Safety Devices	8		
Operating Precautions.....	8		
Setting up your pellet fire	8		
Menu Descriptions.....	8		
Menu One - Setting the Clock	8		
Menu Two - Set Crono (Programmable Thermostat).....	9		
Menu Three - Select Language (Setting the Language)	10		
Menu Four - View Settings	10		
Menu Five - Stove State (Fire Status).....	10		
Menu Six - Working Hours	11		
Description of Screen Displays	11		
Troubleshooting	11		
Explanation of Alarms.....	12		

1. Introduction

Please read this entire manual before operating your Ravelli Wood Pellet Fire. Failure to follow these instructions may result in poor performance, damage to the fire, property damage, bodily injury or even death. Any unauthorised modification of the appliance or use of replacement parts not supplied by the manufacturer is prohibited.

All national and local regulations shall be complied with when installing this appliance. Your local Pellet Fire Solutions dealer will be happy to assist you in obtaining information with regards to your local building codes and installation regulations.

1.1 Specifications

1.1.1 Rating label Location

Ravelli Sara: The rating label is located on the back of unit.

1.1.2 Specifications

Classification	Testing Standard	Description
Class I IP-20	Efficiency: AS/NZS 4012:1999 Appliance: AS/NZS 4013:1999	Residential Wood Pellet Fire
Voltage 220- 240 Volt	Current: 2.92 – 3.18 Amps	Frequency: 50Hz
Max Power Requirement 550 watts	Unit with full hopper: 120kg	Hopper Capacity: 15kg

High

Medium

Low

Mean Flue Gas Temp 191°C	Mean Flue Gas Temp 159°C	Mean Flue Gas Temp 124°C
Fuel Consumption 1.6kg per hour	Fuel Consumption 1.2kg per hour	Fuel Consumption 0.8kg per hour
Heat/Power Output 6.6kw	Heat/Power Output 5.4kw	Heat/Power Output 3.7kw

Average Particular Emissions (dry weight) 0.4gms per kg	Average Emissions Rate 24mg/MJ	Average Efficiency 82%
Gross Calorific Value of pellets (dry weight) 20.1MJ/kg	Fuel Type: Wood pellets: 6mm diameter (complying with standard AS/NZS 4014.6:2008)	

*Note: Consumption will vary with the type of fuel used.

IMPORTANT: The above values were found during testing and may vary with the fuel type, climate and installation style.

2. Safety Warnings & Maintenance Recommendations

2.1 Pellet Quality

Pellet quality is important - please read the following:

Your wood pellet fire has been designed to burn ¼" (6mm) diameter wood pellets, manufactured to the AS/NZS 4014.6 standard only.

The performance of your wood pellet fire is greatly affected by the type and quality of wood pellets being burned. As the heat output of various quality wood pellets differs, so will the performance and heat output of the wood pellet fire.

Caution: It is important to select and use only pellets that are dry and free of dirt or any impurities such as high salt content. Wood pellets manufactured to the AS/NZS 4014.6 standard are recommended. Dirty fuel will adversely affect the operation and performance of the unit and will void the warranty. The Pellet Fuel Industries (PFI) has established standards for wood pellet manufacturers. We recommend the use of pellets that meet or exceed these standards. Ask your dealer for a recommended pellet type.

DO NOT use this appliance as an incinerator.

2.2 Flammable Liquids

Never use gasoline, gasoline-type lantern fuel, kerosene, charcoal lighter fluid or similar liquids to start or "freshen up" a fire in the heater. Keep all such liquids well away from the heater while it is in use.

DO NOT use unsuitable and non-recommended fuels, including liquid fuels, as this will void any warranties stated in the manual.

2.3 Cleaning the fire pot before and after each lighting

You must check that the Burn Pot Liner, where the combustion takes place, is clean and that no waste or residue blocks the holes, in order to always guarantee excellent combustion of the stove. This will help avoid possible overheating, which could cause changes in the colour of the paint, as well as failure to light the stove.



Burn pot liner needing cleaning with holes blocked by ashes



A clean burn pot liner with all the holes clearly visible

Only a clean fire pot can guarantee that the wood pellet fire will function without problems. During functioning, deposits may be formed, which have to be immediately eliminated. It is easy to see when the fire pot has to be cleaned! It only needs a glimpse, each day, before switching on. For minor cleaning, it can be left in the stove, but if the residue is difficult to remove, it has to be extracted from its housing and the waste scraped out.

The ash content of the fuel and operation of your stove will directly determine how frequently you will need to clean out the fire pot. The use of high ash fuels may result in the stove needing to be cleaned daily whereas

a low ash fuel may allow for longer intervals between cleaning.

2.4 Clinkering

Clinkers are silica (sand) or other impurities in the fuel that will form a hard mass during the burning process. This hard mass will block the air flow through the Burn Pot Liner and affect the performance of the stove.

Any fuel, even approved types, may clinker. Check the Burn Pot Liner daily to ensure that the holes are not blocked with clinkers (see above). If they become blocked, remove the liner (when the unit is cold) and clean/scrape clinkers out. Clean the holes with a small

pointed object if required. Refer to the section Routine Cleaning and Maintenance.

Important: Even with a new batch of pellets, although using the same brand, there may be variations in the combustion process, and therefore they may burn either more or less cleanly.

Correct daily cleaning will allow the wood pellet fire to burn properly with high performance, avoiding problems in the long-term which could require the intervention of a technician to repair the wood pellet fire.

3. What are Wood Pellets?

Wood pellets are made from sawdust and wood shavings. The material used cannot contain any foreign substance such as glue, varnish or synthetic substances. Subjecting it to high pressure, the wood is pressed through a plate with holes and due to the high pressure the sawdust is heated activating the natural binders of the wood. Thus, the pellets keep their shape even without the addition of bonding substances.

The density of the wood pellet varies according to the type of wood and can be 1.5 – twice greater than that of natural wood. The diameter of the cylindrical rods is 6-10 mm and their length can vary between 10 and 50 mm. Their weight is equal to about 650 kg/m.

Due to the low content of water (approx 8%) they have a high energy content. The standards AS/NZS 4014.6 define the quality of the pellets.

Do not put the bag of pellets on any part of the fire during the loading operations - hot surfaces can melt pellet packaging.



The pellets must be transported and stored in a dry place. They swell on contact with damp, and cannot be used. They must always be protected from the damp both during transport and in storage. Ravelli recommends using a pellet with a diameter of 6 mm for the stove.

4. Maintenance and Cleaning

4.1 Components of the Fire

This drawing shows the internal parts of a wood pellet fire. By filling the tank (7), the pellets are loaded into the fire pot (3) through the loading screw (1). Ignition is by means of the resistance (2), which overheats the air from the special intake (5) which on contact with the pellets will allow the development of the flame. At this point the exhaust smoke is deviated towards the stainless steel exchanger (6) and through the smoke extraction tube (4) it is released into the flue, through the connection with the smoke exhaust pipe (9).

- | | |
|-------------------------|--------------------------------------|
| 1. pellet feeding auger | 6. heat exchanger (AIR & BOX Models) |
| 2. igniter | 7. pellet hopper |
| 3. burn pot | 8. flame trap |
| 4. exhaust duct | 9. exhaust/flue outlet |
| 5. combustion air inlet | 10. exhaust fan |

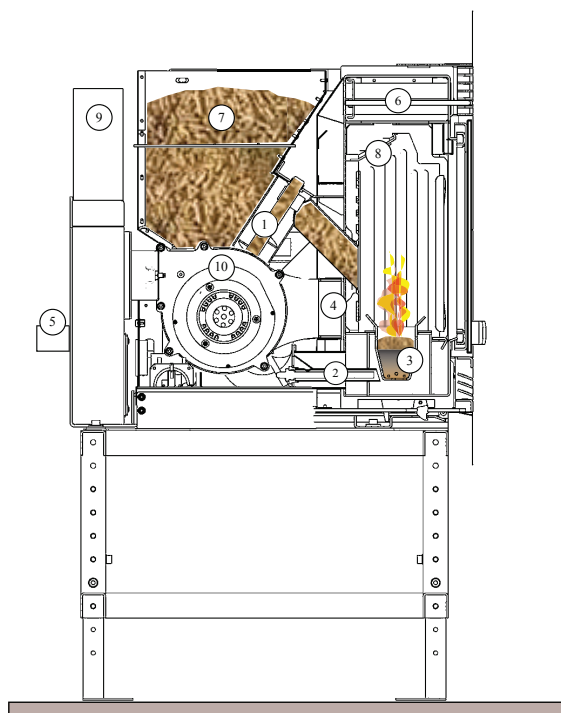

4.2 Before you begin

Before carrying out any maintenance take the following precautions:

- Make sure that the general power supply has been disconnected.
- Make sure that all parts of the wood pellet fire are cold.
- Make sure that the ashes have cooled completely.
- Make sure that the general switch is in the zero position (off).
- Make sure that the plug is disconnected from the socket, thus avoiding accidental electric shocks.
- Always use appropriate tools for maintenance.
- When you have finished re-install all safety guards before using the wood pellet fire again.

The wood pellet fire requires little maintenance if quality wood pellets are used, which is why we recommend pellet fuel that is manufactured to the AS/NZS 4014.6.

4.3 Cleaning the surfaces

To clean the surfaces on the painted metal parts, use a damp cloth.

Important: the use of aggressive detergents or abrasive cleaners can damage the surfaces of the stove.

Warning: parts of the appliance, especially the external surfaces, will be hot to touch when in operation so use due care.

4.4 Responsibility

Pellet Fire Solutions declines all responsibility, both civil and criminal, with the delivery of this manual, for any accidents deriving from partial or total failure to observe the instructions it contains.

Pellet Fire Solutions declines all responsibility deriving from the improper use of the stove, from its incorrect use by the user, by unauthorised modifications and/or repairs or from the use of spare parts which are not original. The manufacturer declines all direct civil or criminal responsibility due to:

- Use of poor quality fuel.
- Poor maintenance.
- Failure to observe the instructions in the manual.
- Use not compliant with the safety instructions.
- Installation that is not compliant with the regulations in force in the country.
- Installation by personnel who are not qualified or authorized.
- Modifications and repairs that are not authorized by the manufacturer.
- Use of spare parts that are not original.
- Exceptional events.

4.5 Spare Parts

To avoid voiding your warranty, use original spare parts only. Do not wait for components to be worn out before replacing them.

Replace a worn component before it is completely broken to prevent any accidents caused by the sudden breakage of components. Perform the periodic maintenance checks as described in the dedicated chapter on Maintenance (page 13).

5. Operating your Pellet Fire

5.1 Starting your Pellet Fire for the first time

1. Load the hopper with pellets (see “5.2 Filling the Pellet Hopper” on page 6)
2. Make sure that the pellet fire is connected to the flue. In the case of an insert pellet fire, the unit must be pushed back and locked securely in its cradle with a good seal on the gasket where the exhaust fan attaches to the flue adapter box.
3. Make sure the power cord is attached, turn the power on and turn the On/Off switch at the back of the fire ON. (The fire will go through its shutdown routine “FINAL CLEANING” with the exhaust/Combustion

fan running for several minutes)

4. Set the clock (see “6.2 Menu One - Setting the Clock” on page 8)
5. Set power level (1-5). For the first start/commissioning it should be on the highest heat setting (level 5).
6. Prime the Auger (see “6.6.1 Loading the Screw (Auger)” on page 10).

Any build up of unburned pellets inside the fire pot after trying to light the fire must be removed before further attempts are made. DO NOT return charred pellets to the hopper.

5.1.1 Starting the fire normally

1. Ensure burn pot is clean and the burn pot holes are visible.
2. Ensure the hopper is full of wood pellets.
3. Press button [3] for 3 seconds. The pellet fire will start its ignition process, going through several ignition phases.
 - **Start – Loads pellets into burn pot, Igniter on but combustion fan off**
 - **Waiting Flame – Pellet loading continues, Igniter on, combustion fan on**
 - **Flame Light – (on sufficient increase in flue temperature) - Loads pellets, Igniter off, combustion fan on**
 - **Work – Pellet loading and combustion/convection fan speed adjusted to power set point**
 - **Final Cleaning - Pellet loading stops, combustion fan on Max speed until pre-set exhaust temp is reached**

5.1.2 Turning the fire OFF

1. Press [3] for 3 seconds.
2. The fire will go into “Final Cleaning” stage.

DO NOT unplug fire or open door until the unit is fully cooled down and both the exhaust fan and convection fan have stopped.

During the working phase, the following settings should be checked and adjusted as required:

- **POWER SETTING (Button 5 on your remote control)**
- **ROOM TEMPERATURE SETTING see “6.3.1 Modifications of the room temperature setting” on page 9.**

5.2 **Filling the Pellet Hopper**

Check hopper for foreign objects, then empty the bag of pellets into the hopper. **DO NOT OVER FILL** as miscellaneous pellets could smoke if left to rest on an operating heater.

Store pellets at least one metre (1m) away from the wood pellet fire.

The Sara insert pellet fire has been designed so it can be pulled out on a runner system so the hopper can be filled with pellets as well as for cleaning and maintenance .

How to extract the stove:

Open the stove door and, using the “T” wrench supplied, fit it onto the square shown in the close-up and turn it in an anti-clockwise direction.

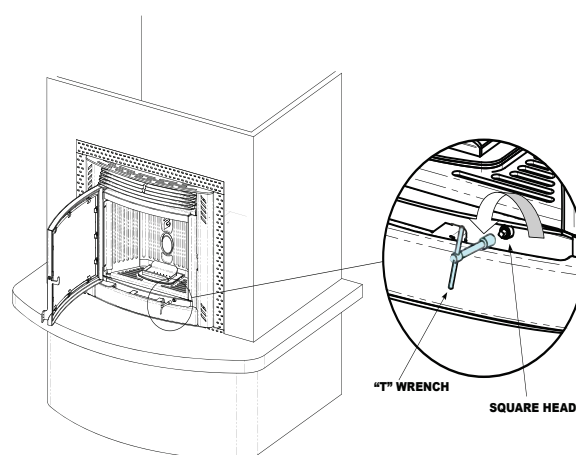

At the same time as the operation described above, pull the stove outwards using the special handle situated behind the ceramic tiles.

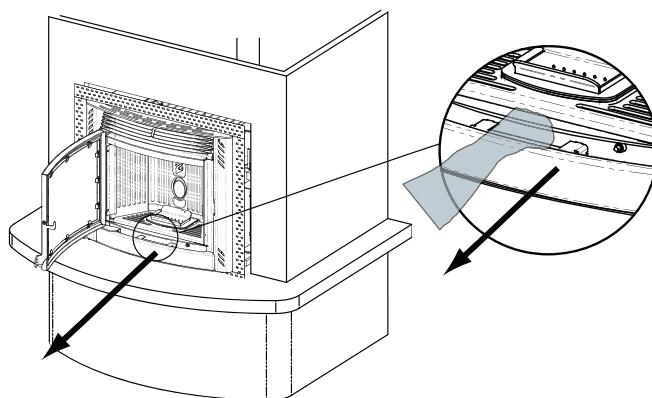

Once the fireplace has been pulled forward, fill the hopper with wood pellets through the safety grill as indicated.

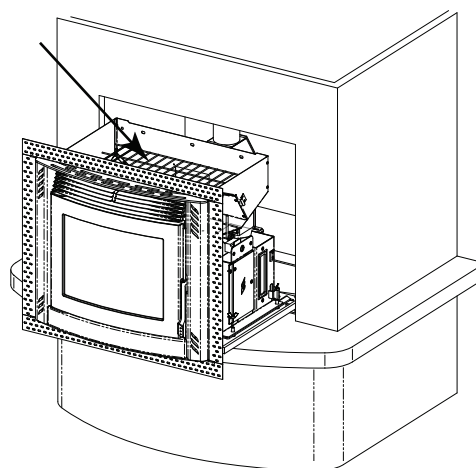

Once the hopper is full, push the fire back into the cavity. When pushing the fire back into position make sure the door is open and the locking mechanism is in the open position. When the fire is in place, turn the

locking mechanism is the locked position before closing the door.

Important: Pushing the fire back in with the locking mechanism closed can cause the fire to jam. Make sure the fire is securely locked in place prior to starting.

5.3 Understanding the Remote Control



Button Number Function

1	Decrease general values
2	Increase general values
3	Turns fire ON/OFF
4	Access to temperature adjustment menu
5	Access to power level adjustment menu
6	Multi-function
7	Multi-function (Enter or Select)

5.4 Synchronising the Remote Control with the Pellet Fire

All insert fires come with a remote-control (radio-wave) handset and receiver. Sometimes, due to interference in the power supply or from other electrical household appliances (microwave ovens, satellite decoders, mobile phones) or replacing the batteries in the remote the connection between the fire and the handset may be interrupted or suffer interference. If this happens, the following operations must be carried out to reinstate the connection:

Note: Make sure the remote has good batteries installed. We recommend replacing the batteries at the beginning of each season. Batteries can be removed if the fire is not being used for prolonged periods, however the remote will probably need re-synchronising once batteries are

reinstalled.

3. Switch the power to the fire off at the mains switch.
4. Press the triangle keys 1 and 2 on the handset together for about 3 seconds. The display will show "SCEGLI UNITA 0"
5. Using triangle key 2, select the unit frequency to be loaded (0 , 1 , 2 , 3) Note: 0 or 1 are usually the best but different houses may work better on other settings.
6. Switch the power to the fire back on (the fire must be pushed back into its cradle when this is done) .
7. Press the red button quickly after tuning the power on.
8. If the operation is successful, UNIT LOADED 0, 1, 2 or 3 will appear on the handset. You may now need to turn the power to the fire off and back on again to refresh the connection with the remote.

5.5 Switching on the Stove

1. Ensure burn pot is clean and the burn pot holes are visible.
2. Ensure the hopper is full of wood pellets.
3. Slide the heat exchange cleaner in and out three times.

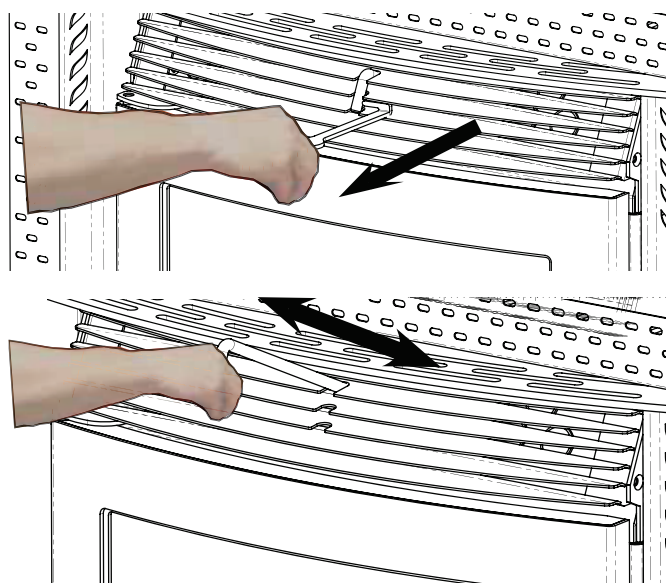

4. To turn unit on hold down button '3' (ON/OFF)
5. Control Screen will show START.
6. To change the Power setting, first press [5] then use buttons [1] or [2] to adjust the heat output of the fire.
7. To change the Thermostat Setting, first press [4] then use buttons [1] or [2] to adjust the thermostat setting.
8. To turn unit off hold down button [3] for three seconds.
9. Control Screen will show FINAL CLEANING.

5.6 Operating Instructions

The heater is completely automated and will self-regulate the ignition phase, five levels of power and the switching off phase, guaranteeing safe functioning. The burn pot used for combustion allows most of the ashes produced by the combustion of the pellets to fall into the lower ash pan. However, it is recommended that you check the burn pot every day, as not all pellets have high standards of quality and could leave residue that is difficult to remove. A special air-circulation function facilitates self-cleaning of the glass, however, a slight greyish film cannot be avoided after a few hours of functioning.

Pellets with a diameter of 6mm, manufactured to the AS/NZ 4014.6 or higher must be used with the stove.

5.7 Safety Devices

The heater is fitted with sophisticated safety systems so that, in the case of breakage of one of the individual

.....

6. Setting up your pellet fire

All operations assume the fire is in the default OFF mode - press button 3 to achieve this. Some operations can also be performed in final cleaning – use caution if the fire has been running. If the fire should come with the wrong language set see “6.4 Menu Three - Select Language (Setting the Language)” on page 10.

6.1 Menu Descriptions

The fire has various functions arranged in different menus. Some of these menus are accessible by the user, others are protected by a password and accessible only by a qualified technician.

Press button [7] for 3-4 seconds to access the menus, then use buttons [1] and [2] to scroll through the options, and button [7] to Enter/Select.

The menus are as follows:

Menu 01	Set Clock
Menu 02	Set Crono (Programmable Thermostat)
Menu 03	Select Language
Menu 04	View Settings
Menu 05	State Stove (Fire Status)
Menu 06	Hours Work
Menu 07	Bank Data (protected by a password)
Menu 08	Reset Hours (protected by a password)
Menu 09	Default Settings (protected by a password)
Menu 10	Select Recipe (protected by a password)

parts or defects in the flue, no damage will be caused to the stove and the room in which it is installed. In any case, when a problem arises, the pellets stop falling immediately and the switch off phase is activated. The corresponding alarm will be shown on the display. The details can be seen in the “7.1 Explanation of Alarms” on page 12.

5.8 Operating Precautions

- In case of faulty operation turn the stove off pressing button no. 3.
- Do not manually load the fire pot with pellets.
- Any build up of unburned pellets inside the fire pot after repeatedly trying to light the stove, must be removed before further attempts.
- Do not use any fuels other than wood pellets.
- Should the ignition system be faulty, do not attempt to light the stove using flammable materials.

6.2 Menu One - Setting the Clock

To set the clock, proceed as follows:

1. Remove and reset the electric supply of the stove using the general switch on the back.
2. The display will show FINAL CLEANING and then OFF.
3. Press button [7]. (Menu 01 Set Clock will appear)
4. Press [7] to enter into this menu. DAY CLOCK will appear:

Display	Meaning
01	Monday
02	Tuesday
03	Wednesday
04	Thursday
05	Friday
06	Saturday
07	Sunday
OFF	Deactivated

5. Set the desired day by using [1] or [2] according to the table shown below.
6. Press [7] to confirm
7. TIME CLOCK will appear on the display and the current time will be shown. Change the hours of the

day with [1] or [2] (24 hour clock) example: 4:30p.m would be 16:30

8. Press [7] to confirm
9. MINUTES CLOCK will appear on the display. Change the minutes of the day with buttons [1] or [2]
10. Press [7] to confirm
11. Press [3] to exit the menu

6.3 Menu Two - Set Crono (Programmable Thermostat)

By using the built-in programmable thermostat you can program your pellet fire to turn on/off automatically on different days of the week, with two separate on/off times.

Example: Program 1. Start at 06:00 and Stop at 08:30; Program 2, Start at 16:00 and Stop at 22:00.

To enter this menu, proceed as follows:

1. Press button [7] (Menu 01"Set Clock" will appear)
2. Press button [1] once you see (Menu 02 Set Crono)
3. Press button [7] to enter into this menu
4. Use Button [1] or [2] to set the time you want the fire to start (time is in the 24 hour clock). Press [7] to confirm
5. Use Button [1] or [2] to set the time you want the fire to stop. Press [7] to confirm.



6. Now use [5] to scroll through the days you want the fire to operate with this program and use [4] to set the days to ON or OFF. Press [7] to confirm
7. Use [1] or [2] to set the power that you want the fire run on (1- 5)



If this black line is not lit up the timer function will not be active. To activate this line you must first set the day and time. See "6.2 Menu One - Setting the Clock" on page 8.

8. Press [7] to confirm.
9. Use [1] or [2] to set the room temperature that you would like the fire to reach.
10. Press [7] to confirm

11. Repeat steps 4 through 10 to set program 2 (if required)
12. Once you have completed setting up program 2 Press [3] to exit

Possible Settings

Description	Values that can be set
START PROG -1	From OFF to 23.50 hours
STOP PROG -1	From OFF to 23.50 hours
DAY PROG -1	ON or OFF, Monday-Sunday
POWER PROG -1	From 1 to 5
TEMP ROOM PROG -1	From 7°C to 40°C
START PROG -2	From OFF to 23.50 hours
STOP PROG -2	From OFF to 23.50 hours
DAY PROG -2	ON or OFF, Monday-Sunday
POWER PROG -2	From 1 to 5
TEMP ROOM PROG -2	From 7°C to 40°C

Important: When using the Programmable Thermostat mode, you must make sure that after each time the stove is automatically switched off, the burn pot remains clear in order to guarantee correct automatic ignition.



Burn pot liner needing cleaning with holes blocked by ashes



A clean burn pot liner with all the holes clearly visible

6.3.1 Modifications of the room temperature setting

The hand held remote that controls the fire also has a thermostat built in which measures the ambient temperature. The room temperature will be shown on the display. For the thermostat to control the pellet fire's heat output, the remote must be left in a suitable place in the room where it can measure the typical room temperature.

Note: DO NOT leave the remote down the side of the sofa, on a window ledge or in a cold draft, in another room, or in the flow of hot air coming off the fire. These will give false readings and the fire will not control the room temperature correctly.

To set the desired temperature press button [4] then use button [1] & [2] to achieve the desired value. When the set temperature on the display is reached, MODULATION WORK will appear on the screen and the fire will drop to its lowest power setting.

6.4 Menu Three - Select Language (Setting the Language)

Some fires may be in their default Italian language, if so proceed with Instruction Set 'A'.

If not, please use Instruction Set 'B'.

A. Setting fire from Italian language to your desired language. (English, German, French, Danish)

1. Press button [7] (Menu 01 "Set Orologio" will appear)
2. Press button [1] twice until you see (Menu 03 "Scegli Lingua")
3. Press [7] to enter into this menu ("Italiano Lingua" should appear)
4. Press [1] or [2] until you see "English Lingua" or select your desired language.
5. Press [3] twice to return to the main screen.

B. Setting fire from English language to your desired language. (Italian, German, French, Danish)

1. Press button [7] (Menu 01 "Set Clock" will appear)
2. Press button [1] twice until you see (Menu 03 "Select Language")
3. Press [7] to enter this menu ("English Lingua" will appear)
4. Press [1] or [2] to change to your desired language.
5. Press [3] twice to return to the main screen.

6.5 Menu Four - View Settings

In this menu you can check the values of the parameters set in the control unit. This menu is used when a Service Technician has to understand the parameters set in the machine, to find any modifications to improve the functioning of the stove.

6.6 Menu Five - Stove State (Fire Status)

In this menu, you can check the correct functioning of some of the key components of the pellet fire.



To enter this menu either

1. Press Button [7] (Menu 01 "Set Clock" will appear)
2. Then press and hold [6] for 3 seconds

Or

1. Press [7] CLOCK SETTING MENU will appear
2. Press [1] four times "fire State" menu, enter using [7].

This menu is for use by a service technician for commissioning and diagnostics, and for the customer when loading pellets into the auger when the fire has been completely run out of fuel.

6.6.1 Loading the Screw (Auger)

Insert Models - Loading the Auger should only be carried out in OFF mode

When the stove is new or the fire has run out of fuel, the auger will be empty. In this case it may be necessary to 'load' the auger so the fire will start.



To load the screw/auger, proceed as follows:

1. Press Button [7] (Menu 01 "Set Clock" will appear),

then press and hold [6] for 3 seconds. The display will show "SCREW STATE".

2. Use Button [1] to turn the Auger On "SCREW 1" and button [2] to turn it OFF.
3. Once started auger will run for a couple of minutes
4. Remember to turn the screw OFF (SCREW 0) with button [2] before exiting, button [3]
5. Empty the burner pot of any pellets before starting the fire

Also see "6.6 Menu Five - Stove State (Fire Status)" on page 10.

6.8 Description of Screen Displays

SCREEN DISPLAY	DESCRIPTION
FINAL CLEANING	The stove is switching off, the cooling phase is not yet completed
LIGHT	The ignition phase has started, the pellets are loaded into fire pot
WAIT FOR FLAME	The pellet's are ignited by the hot air passing through the ignition candle
FLAME PRESENT	The flame is visible in the fire pot
WORK	The stove has completed the switch ON phase; you can now change the power
MODULATION WORK	The set room temperature has been reached
T ON	The room sensor is off or an external thermostat has been connected
COOLING/WAITING FOR START	The stove is cooling DOWN. When stove has cooled down it will start automatically.
ON/WAITING FOR RESTART	The switch ON phase, when the stove is warm, started. The operation is same as phase ON
HOT SMOKE	The max temperature of smokes is reached: to reduce temperature, feeding pellets and air draft reduce at POWER 01
OFF	The stove is off

7. Troubleshooting

In the event of a problem with the fire it will sound an alarm and display a fault code and description, see "7.1 Explanation of Alarms" on page 12 for more information on the cause and what to do.

The fault can be cleared by pressing and holding button [3] on the remote. Note which fault is displayed on the screen before re-setting the alarm.

For basic faults follow the steps to resolve the problem and try restarting the fire. For more complex issue contact your local dealer / service agent.

If the fire gets too hot this will trip a safety device and display "THERMAL ALARM". The safety device will

6.7 Menu Six - Working Hours

The WORKING HOURS Menu shows the total run hours done by the fire.

To enter this menu, proceed as follows:

1. Press Buttons [7] (Menu 01 "Set Clock" will appear).
2. Press button [1] twice until you see (Menu 06 "WORKING HOURS MENU).
3. Press [7] to enter this menu .
4. Press [3] to return to the main screen.

need to be manually re-set before the fire will work. This is located under the black cap above the electronics panel (see below).

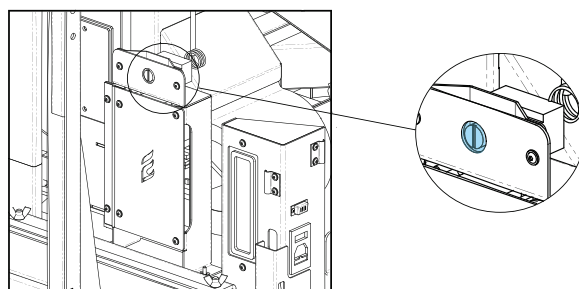

Unscrew the protection cap and press the button to

reset the thermostat alarm. Make sure you ascertain the reason for this safety device to trip before restarting the fire.

7.1 Explanation of Alarms

WARNING	REASON	SOLUTION
PELLETS FINISHED ALARM	<ul style="list-style-type: none"> The pellet hopper is empty 	<ul style="list-style-type: none"> Check whether there are pellets in the hopper and refill if necessary.
	<ul style="list-style-type: none"> The raio-motor does not load pellets. 	<ul style="list-style-type: none"> Empty the hopper to check that no foreign objects have fallen inside which could prevent the correct functioning of the auger.
	<ul style="list-style-type: none"> Pellets not loading. 	<ul style="list-style-type: none"> Contact local Service Technician
		<ul style="list-style-type: none"> IF THE PROBLEM CONTINUES, CONTACT YOUR LOCAL SERVICE TECHNICIAN.
BLACK - OUT	<ul style="list-style-type: none"> No electricity supply during working phase. 	<ul style="list-style-type: none"> Press the off button and repeat switching on the stove.
		<ul style="list-style-type: none"> IF THE PROBLEM CONTINUES, CONTACT YOUR LOCAL SERVICE TECHNICIAN.
NO IGNITION ALARM	<ul style="list-style-type: none"> The pellet hopper is empty 	<ul style="list-style-type: none"> Check whether there are pellets in the hopper and refill if necessary.
	<ul style="list-style-type: none"> Setting of pellets and of intake during ignition phase insufficient 	<ul style="list-style-type: none"> Contact local Service Technician.
	<ul style="list-style-type: none"> The ignitor is defective 	<ul style="list-style-type: none"> Contact local Service Technician.
LOW FLAME ALARM	<ul style="list-style-type: none"> The pellet hopper is empty 	<ul style="list-style-type: none"> Check whether there are pellets in the hopper and refill if necessary.
	<ul style="list-style-type: none"> Bad setting of pellet and air during ignition 	<ul style="list-style-type: none"> Contact local Service Technician.
FAN RPM ALARM	<ul style="list-style-type: none"> The revolution of smoke fan lowering more than 15% of speed to fan congestion 	<ul style="list-style-type: none"> Contact local Service Technician.
FAN BROKEN ALARM	<ul style="list-style-type: none"> Smoke extractor encoder is not functioning or not correctly connected 	<ul style="list-style-type: none"> Contact local Service Technician.
	<ul style="list-style-type: none"> No electricity supply to smoke extractor 	<ul style="list-style-type: none"> Contact local Service Technician.
	<ul style="list-style-type: none"> The smoke extractor is blocked 	<ul style="list-style-type: none"> Contact local Service Technician.
DEPRESSION ALARM	<ul style="list-style-type: none"> The combustion chamber is dirty 	<ul style="list-style-type: none"> Follow the cleaning operations of the stove as per the instructions manual.
	<ul style="list-style-type: none"> The flue is blocked 	<ul style="list-style-type: none"> Check that the flue is clear and clean.
	<ul style="list-style-type: none"> The vacuum switch is malfunctioning 	<ul style="list-style-type: none"> Contact local Service Technician.
THERMAL ALARM WITH RESET	<ul style="list-style-type: none"> The thermostat with manual reset has intervened 	<ul style="list-style-type: none"> Reset the thermostat pressing the button on the back of the stove.
	<ul style="list-style-type: none"> The centrifugal fan is defective 	<ul style="list-style-type: none"> Contact local Service Technician.
	<ul style="list-style-type: none"> Combustion in the fire pot is not optimal 	<ul style="list-style-type: none"> Switch off the stove, clean the fire pot and regulate combustion with the setting of the pellets.
HOT SMOKE ALARM	<ul style="list-style-type: none"> Combustion in the fire pot is not optimal 	<ul style="list-style-type: none"> Switch off the stove, clean the fire pot and regulate combustion with the setting of the pellets.
	<ul style="list-style-type: none"> The centrifugal fan is defective 	<ul style="list-style-type: none"> Contact local Service Technician.
		<ul style="list-style-type: none"> IF THE PROBLEM CONTINUES, CONTACT YOUR LOCAL SERVICE TECHNICIAN.
SMOKE SENSOR ALARM	<ul style="list-style-type: none"> The smoke sensor is malfunctioning 	<ul style="list-style-type: none"> Contact local Service Technician.
	<ul style="list-style-type: none"> The smoke sensor has been disconnected from the board 	<ul style="list-style-type: none"> Contact local Service Technician.
AUGER BLOCKED ALARM	<ul style="list-style-type: none"> The auger does not load pellets 	<ul style="list-style-type: none"> Contact local Service Technician.

8. Maintenance and Cleaning

Before carrying out any maintenance take the following precautions:

- Make sure that the general power supply has been disconnected.
- Make sure that all parts of the wood pellet fire are cold.
- Make sure that the ashes have cooled completely.
- Make sure that the general switch is in the zero position (off).

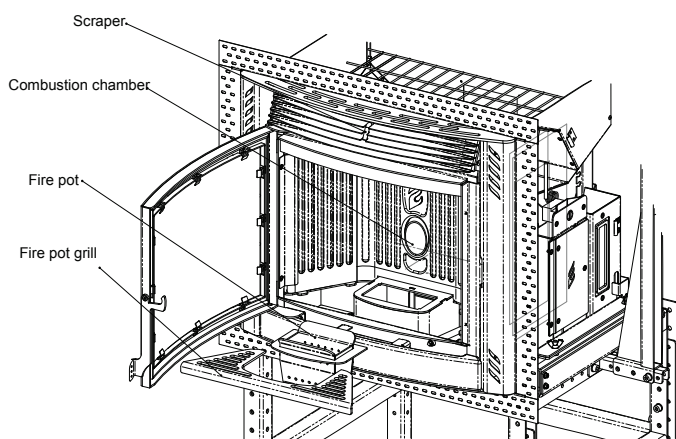

- Make sure that the plug is disconnected from the socket, thus avoiding accidental electric shocks.
- Always use appropriate tools for maintenance.
- When you have finished re-install all safety guards before using the wood pellet fire again.

The wood pellet fire requires little maintenance if quality wood pellets are used which is why we recommend pellet fuel that is manufactured to the AS/NZS 4014.6.

IMPORTANT: the fire should be cold and the plug removed from the power supply for any maintenance.

NOTE: Do not use abrasive or solvent based cleaners to clean any part of the pellet fire.

The following list of components should be inspected and maintained routinely to ensure that your pellet fire is operating optimally and giving you the best efficiency.

Parts/Frequency	1 Day	3-5 Days	30 Days	Yearly	Performed By
Burn pot	•				Owner
Ashpan	•				Owner
Firebox and flame trap		•			Owner
Door Glass		• (or as required)			Owner
Seals & Gaskets			•		Owner/Technician
Pellet Hopper			•		Owner/Technician
Fresh Air Intake				•	Owner/Technician
Blower Mechanisms				•	Technician
Fire exhaust passages				•	Technician
Flue system				•	Technician

Frequency recommendations given are based on typical fire performance and maybe shorter or longer dependent on fuel quality, fire performance and run hours.

Your pellet fire burns solid fuel and as such requires servicing by a qualified person at least once a year - generally over the summer or at the start of the season. The purpose of this maintenance is to make sure that the fire is in good working order and is safe and ready for the heating season.

We recommend you draw up an annual contract for maintenance of the fire with your installer/dealer.

8.1 Burn Pot Liner (daily)

This is the 'pot' where the pellets are burned. The burn pot liner should be inspected every time you start the fire (when the unit is cold), to ensure all the holes are free to allow correct air flow for combustion. Failure to keep the burn pot liner clean may cause a build-up of fuel above the burn pot liner and up the pellet feed tube. This will cause the auger to jam and may result in pellets burning in the pellet feed tube and hopper. Keeping the burn pot liner clean will help avoid possible overheating, which could cause changes in the colour of the paint, as well as ignition failures.

For light deposits the burn pot liner can be scraped out in situ with the scraper tool provide. For heavier deposits and thorough weakly cleaning it should be removed.

To remove the burn pot liner, open the door and lift the burn pot liner from the burn pot holder.



Burn pot liner needing cleaning with holes blocked by ashes



A clean burn pot liner with all the holes clearly visible

Using the metal scraper or suitable tool (wire brush) remove material that has accumulated in the burn pot liner or is clogging the holes, then dispose of the scrapped ashes. Place the burn pot liner back into burn pot holder, making sure that the igniter hole is aligned with the igniter tube, then push the burn pot liner back up against the igniter tube.

Note: If after long periods of burning, the flame is a tall, lazy flame with dark orange tips and the fire builds up and overflows the burn pot or there is a build-up of clinkers, this is an indication that fire may need to be shut down and cleaned.

CAUTION: BECAUSE THE FLY ASH IS VERY FINE, THE USE OF A BAGGED VACUUM CLEANER IS RECOMMENDED. BAG-LESS VACUUMS CAN BE DAMAGED BY THE FINE ASH. Please pay special attention that there are no hot ashes or there could be a possibility of a fire hazard inside the vacuum cleaner. Place all hot ashes into a non-combustible container.

8.2 Heat Exchanger Tubes (daily)

The handle for the heat exchanger cleaning rod is pointed out in the first image below. This handle is to be pulled back and forth a few times (ONLY WHEN THE UNIT IS COLD) in order to clean away any fly ash that may have collected on the heat exchanger tubes. As different types

of pellets produce different amounts of ash, cleaning of the tubes should be done on a regular basis to enable the unit to run efficiently. Use the supplied scraper tool to access the handle.

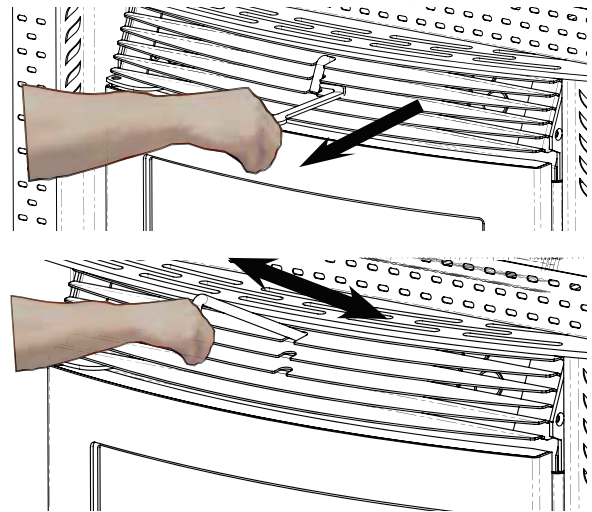

8.3 Firebox, Flame Trap, Burn Pot Holder and FIREX Lining (3-5 days)

Dependent on fire use and fuel quality, the insides of the fire box should be cleaned out once every 3-5 days. This includes the burn pot holder.

To do this lift the burn pot liner from the fire and clean out the burn pot holder of ash - the easiest way of doing this is to vacuum it out. Make sure the air intake is clear of ash or debris - this can also be vacuumed out to ensure it is clean.

Place the burn-pot back into the fire, making sure that the burn pot is located correctly.

The Flame Trap located in the top of the burn chamber, below the heat exchanger tubes, should be removed and the ash which has been scraped off the heat exchanger tubes cleaned off. The heat exchanger tubes can also be brushed clean with a soft brush.

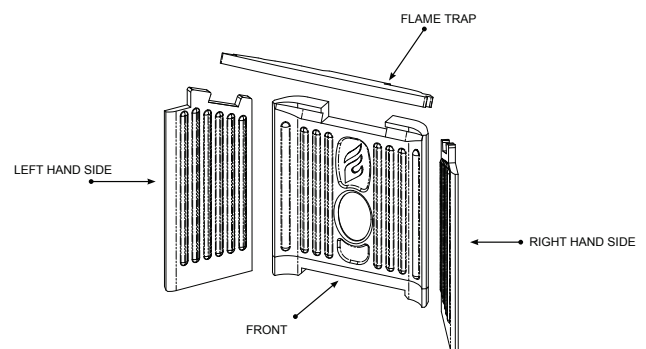

All Ravelli products have a combustion chamber made with FIREX 600, a material based on vermiculite, the result of research and development by Ravelli. The main features of FIREX 600 are resistant to heat, its lightness and excellent insulating capacities, improving

the combustion and performance of the fire.



During combustion, FIREX 600 turns white, due to an effect called PYROLYSIS, making the flame clear and shining. If the combustion is regulated correctly, the FIREX 600 interior always

remains clean and white.

The condition of FIREX 600 is therefore a gauge to understanding whether the combustion is good or not.

FIREX 600 LIGHT - EXCELLENT COMBUSTION

FIREX 600 DARK - POOR COMBUSTION

FIREX 600 does not require special maintenance, it only has to be dusted with a brush to remove the ash that is deposited during combustion.



Abrasive sponges should not be used as they could compromise the thickness of the FIREX600 panel.

The tube of the vacuum cleaner should not be used in direct contact with FIREX 600.

Wet cloths should not be used to clean FIREX 600.

FIREX 600 is resistant to heat but can still break; handle with care.

FIREX 600 may show a slight abrasion after a few hours of functioning, this is perfectly normal as the flame creates microgrooves in the panel without compromising it.

The duration of FIREX 600 depends only on how maintenance is carried out.

8.4 Ash Pan (3-5 days)

Monitor the ash level every week. Remember that different pellet fuels will have different ash contents. Ash content is a good indication of fuel efficiency and quality. Refer to "Warnings and Recommendations" for disposal of ashes. **DO NOT PLACE UNBURNED OR RAW PELLET FUEL IN THE ASH PAN.** Vacuum the ash pan and inside the pedestal.

8.5 Door Glass (3-5 days or as required)

The fire is designed to keep the glass as clean as possible while the fire is in operation, a flow of air runs along the surface of the glass keeping ash and dirt away. However, a greyish patina will form after a few hours. A poorly performing fire will get brown or black deposits on the glass.

The glass must be cleaned only when the fire is cold, using a damp cloth or kitchen paper. Sometimes it is best to dirty the cloth slightly with ash from the fire itself to create a slightly abrasive action which will help to remove stubborn deposits.

NOTE: Do not attempt to light the fire if the glass is broken.

The door glass is made of special high temperature PYROCERAMIC. The use of substitute materials is prohibited use only official Ravelli replacement parts

8.6 Seal & Gaskets (monthly)

Regularly check the condition of the door seals, gaps or damaged / loose seals may cause a loss of vacuum in the burn chamber and result in poor combustion. To repair or replace this, glue the gasket on, using high temperature fiberglass gasket glue see your local dealer for details.

8.7 Pellet Hopper (monthly)

The quality of the pellets being used is very important as this affects the heat output of the fire and the cleaning requirements. Fuel quality can vary between manufacture and even between batches from the same manufactures. If you have an excess of fines (sawdust) in the bag this builds up in the bottom of the hopper and can jam the auger over time. We recommend that once a month you run the fire out of fuel and vacuum any accumulated fines (sawdust) from the bottom of the hopper to prevent any issues.

8.8 Fresh Air Intake (yearly or as required)

Inspect periodically to be sure that it is not clogged with any foreign materials.

8.9 Flue System (yearly)

The products of combustion will contain small particles of fly ash. The fly ash will collect in the flue system and restrict the flow of the flue gases. Incomplete combustion, such as occurs during start up, shutdown, or incorrect operation will lead to some soot formation which will also collect in the exhaust venting system. The exhaust

venting system should be inspected and cleaned at least once every year or after every ton of pellets burnt. We recommend contacting your dealer for professional cleaning. To remove dust from the vent pipe, tap lightly on the pipe to dislodge any loose ash. Open the bottom of the flue adapter box and vacuum as much of the ash out of the vent pipe as possible.

8.10 Blower Mechanisms (yearly)

Pull the fire forward to access the two blowers. Vacuum all dust from motors and convection fan blades. DO NOT lubricate these fans they have sealed bearings.

8.11 Post season clean-up

Once you are finished using the pellet appliance for the season, unplug the fire for added electrical protection. It

.....

is very important that the fire be thoroughly cleaned and serviced as stated above. Exposed metal part may be painted with high temperate paint to prevent rusting over the off season.

8.12 Cleaning the surfaces

To clean the surfaces on the painted metal parts, use a damp cloth.

Important: the use of aggressive detergents or abrasive cleaners can damage the surfaces of the stove.

10. Manufacturer Warranty Policy

Pellet Fire Solutions is committed to quality and customer service of the highest level. Our products are backed by manufacturer warranty policies and processes that aim to provide comprehensive, straightforward, fair and reasonable cover for our customers.

This manufacturer warranty policy (**Policy**) covers defects in materials and workmanship of pellet fires supplied by Pellet Fire Solutions to a dealer (**Dealer**). This Policy details only those warranties provided by the applicable manufacturer (**Warranty**), not Pellet Fire Solutions, and is subject to the conditions set out below.

10.1. Warranty Process Overview

In order to qualify for the Warranty, the following process must be followed:

1. Products must be installed by authorised Pellet Fire Solutions installers in accordance with all applicable regulations, standards and product manual information.
2. An “*Installation and Commissioning Form*” must be completed and sent to Pellet Fire Solutions not later than 1 month after the install date.
3. Any defect identified by a customer must be assessed by their Dealer.
4. The Dealer should then check the install dates and the Warranty policy terms (including the applicable period, amount, and limitations) to determine if the identified defect is covered by a Warranty. The Dealer should also check with Pellet Fire Solutions and if applicable agree on any non-standard claims, in writing in advance to submitting a claim (**Claim**).
5. All Claims must be submitted in writing to Pellet Fire Solutions. Pellet Fire Solutions will liaise with the applicable manufacturer to determine whether the Claim is covered by a Warranty.
6. If the identified defect is not covered under Warranty or if Pellet Fire Solutions does not accept the Claim, the Dealer should quote the cost of any repairs to the customer directly before proceeding to repair the defect.
7. If the defect is covered by the Warranty and the Claim is accepted by Pellet Fire Solutions, the Dealer should order any required parts and promptly repair the defect.
8. The Dealer should also promptly send a “*Warranty Claim Application Form*” with the required information to Pellet Fire Solutions.
9. Pellet Fire Solutions will reimburse the Dealer on the 20th of the month following the date of acceptance of the Claim.

The first point of contact for actioning all Warranty Claims is Pellet Fire Solutions. They will advise the Dealer on the best course of action and in the event that they are unable to resolve the issue directly, they will liaise with a Technician to achieve a solution.

10.2. Warranty Cover

The table below details the cover for key components. Please take note of the comments to the right and other clarifications or exclusions within this Policy.

This Warranty relates only to components supplied to the Dealer by Pellet Fire Solutions. The cover may vary from time to time in accordance with the details of each manufacturer's Warranty.

The Warranty is limited to the amounts set out in the table below and Pellet Fire Solutions will not be responsible for reimbursement of removal, re-installation, travel or freight costs in excess of these amounts, without prior written approval by Pellet Fire Solutions.

If the Dealer believes they have a valid Claim for amounts and cover outside those specified in this policy, the Dealer must contact Pellet Fire Solutions for pre-approval **prior to work being started**. Any approved variations must be in writing and based on direct variable cost compensation (for example, hourly rates at cost not full retail margin and variable vehicle running costs e.g. 25 cents per kilometre in accordance with the AA 2010 Diesel Running Cost report).

Enviro and Ecoteck Pellet Fires only

	Labour¹	Parts²	Period³	Comments
Fireplace, stovebody and parts covering: - Firebox, - Heat exchanger - Pedestals, Panels & Legs	Standard Flat Rate or Service Flat Rate ¹	Full replacement	5 years parts 2 years labour	Surface finishes, bumpot liner and ceramic panels are covered separately (see clarifications and exclusions below).
Electrical items covering: - Ignitor (including tube) - Auger Motor - Circuit Board, decal & mounting bracket - Blowers (Convection and Combustion) - Timers - Sensors - Wire harness	Flat Rates as above	Full replacement	2 years parts & labour	
Replacement/spare Parts: - All replacement parts beyond their original warranty period or purchased new from a Dealer.	None	Full replacement	1 year	Evidence of the original purchase date will be required e.g. a copy of the original invoice.

Clarifications and exceptions:				
Bumpot Liner and Brick Liner	Flat Rates as above	Full replacement	1 years parts & labour	Paint on the brick firebox lining may peel over time due to the extreme conditions and is not a flaw.
Exterior surface finishes (including plating, enamel or paint).	Flat Rates as above	Full replacement	1 years parts & labour	Colour changes with heating and tarnish, discolourisation and wear (including scratches, fingerprints etc.) are not covered under warranty.
Exclusions				
Glass & Paint Finishes	No warranty			
Vermiculite (Firex 600) & ceramic panels (cast majolica)	No warranty			
Fibreglass rope gaskets	No warranty			

¹ **Labour:** These flat rates (before GST) are set to provide a simple compensation to the Dealer for their variable warranty costs “on-average” over time. They include an allowance for travel costs and time. Only one flat rate applies per Claim i.e. multiple parts or multiple trips to complete the job do not receive multiple flat rates. The Service Flat Rate shall apply if the warranty work is performed as part of a service job being charged to the end customer.

² **Parts:** Full replacement includes free of charge delivery to the Dealer. Pellet Fire Solutions requests that all faulty components are returned to Pellet Fire Solutions or retained for pick up. A copy of the “*Warranty Claim Application Form*” (marked copy) needs to be attached to each faulty component. Pellet Fire Solutions reserves the right to provide an as-new repaired item.

³ **Period:** The effective period is from the following date being the later of:

- the date of the installation of the fire; or
- the date of the installation of a previous replacement of the same part number (if applicable).

However, if the install date has not been advised with the “*Installation and Commissioning Form*” then the effective period will be from the date of despatch from Pellet Fire Solutions to the Dealer.

Should any part of the complete heating system be replaced during the Warranty period, the balance of the original warranty will continue to remain effective.

10.3. Exclusions, limitations and clarifications *General*

1. This Policy applies only to products purchased through an authorised Pellet Fire Solutions Dealer and installed by a qualified authorised Pellet Fire Solutions installer.
2. The product must be installed in accordance with local and national regulations, standards and the product manual instructions.
3. An "*Installation and Commissioning Form*" must be completed by the Dealer and sent to Pellet Fire Solutions no later than 1 month after the install date.
4. Warranties do not cover any damage caused during the installation or transit.
5. All products must be inspected by the Dealer on arrival at its store. Any defects must be reported in writing to Pellet Fire Solutions within two working days. Warranties do not cover labour or travel for faults or defects that should reasonably have been detected during this inspection.
6. The product must be operated, maintained and serviced in accordance with the instructions in the Owner's Manual. Warranties will not apply if the product is damaged or broken as a result of an act or omission of a third party, nor as a result of any alteration, wilful abuse, mishandling, accident, neglect or misuse of the product.
7. This Warranty does not cover products made or supplied by other companies and used in conjunction with the operation of this product without prior written authorisation from Pellet Fire Solutions.
8. Pellet Fire Solutions excludes all statutory and other implied warranties to the fullest extent permitted by law. Pellet Fire Solutions will not be liable for claims for death, personal injury, damage to property or consequential loss to the fullest extent permitted by law.
9. The Dealer acknowledges that it shall purchase the products for the purposes of a business and that pursuant to section 43(2) of the Consumer Guarantees Act 1993 it is agreed that none of the provisions of that Act apply to this Warranty or in respect of the sale of any products by Pellet Fire Solutions to the Dealer.
10. The Warranty is automatically voided if the product serial number is removed or altered in any way.
11. Pellet Fire Solutions may at its sole discretion replace or repair the product (or component). Pellet Fire Solutions reserves the right to supply alternative replacement parts provided that the products are of the same or similar quality and are fit for the purposes for which they were intended.
12. Pellet Fire Solutions and the original product manufacturers are at liberty to alter the design or construction of the products, including for sales orders still to be delivered provided that the products are of the same or similar quality and are fit for the purposes for which they were intended. Such alterations shall not constitute a defect under any Warranty.
13. This Warranty is applicable only to the original purchaser, at the original site of installation and it is non-transferable.

14. Pellet Fire Solutions reserves the right to make changes to this Policy and any of the Warranties from time to time by written notice.

Product specific

1. This Policy does not cover environmental conditions or force majeure events beyond Pellet Fire Solutions control, including but not limited to strikes, lock-outs or other industrial disputes, failure of a utility service or transport network, act of God, war, riot, civil commotion, malicious damage, compliance with any law or governmental order, rule, regulation or direction, accident, breakdown of plant or machinery, fire, flood, earthquake, storm or default of suppliers or sub-contractors high levels of humidity, salt air, chlorine, dampness and condensation; power fluctuations or power surges, wind, inadequate venting or ventilation, excessive offsets, negative air pressures or other influences caused by fans, and clothes dryers.
2. Pellet fires supplied by Pellet Fire Solutions have been designed to burn wood pellet fuel that complies with the wood pellet fuel standard AS/NZS 4014.6:2007. The Warranties contained in this Policy will not apply if wood pellet fuel is burnt that does not meet this standard.
3. The Warranties are based on typical residential usage of up to one tonne of fuel per year and void if the pellet fire is not serviced annually.

11. Proof of Purchase/Warranty

Use this page to note down the details of your wood pellet fire purchase, and attach the receipt and any other documents/ business cards from the retailer that sold you the fire.

Name of Store where Pellet fire was purchased:

Date of Purchase:

Amount Paid: \$.....

Payment Method: Credit Card EFTPOS Cash Other

Installation Section - Table of Contents

Introduction.....	22	Flashing Options	31
Dimensions (Ravelli Sara)	22	Flueing.....	32
Positioning and Installation of the wood pellet fire	23	Controls and Menus	33
Positioning	23	Description of Controls	33
Installing.....	23	Turning the Unit On.....	33
Safety Warnings and Maintenance Recommendations	24	Menu Descriptions	33
Pellet Quality.....	24	Programming & Commissioning.....	36
Spare Parts.....	24	Sara Parameters - version BOX 03	36
Responsibility.....	24	Technical Drawings	38
Flammable Liquids.....	25	Producer Statement and Warranty Registration Form	39
Dimensions - Sara Insert Pellet Fire	25		
Creating the Cavity.....	26		
Architectural Drawings	28		
Example of Cavity Design - Section View.....	28		
Example of Cavity Design - Top View	29		
Adjusting the Support Frame	30		
Seismic Restraint	30		
Fixing to Concrete Floor	30		
Fixing to Timber Flooring only	30		
Fixing to Timber Floor Framing	30		
Ventilation	30		
Television Clearances	31		

1. Introduction

This manual is designed for the technician/installer.

Please read this entire manual before operating your Ravelli Wood Pellet Fire. Failure to follow these instructions may result in poor performance, damage to the fire, property damage, bodily injury or even death. Any unauthorised modification of the appliance or use of replacement parts not supplied by the manufacturer

is prohibited.

All national and local regulations shall be complied with when installing this appliance. Your local Pellet Fire Solutions dealer will be happy to assist you in obtaining information with regards to your local building codes and installation regulations.

1.1 Dimensions (Ravelli Sara)



The data shown are indicative and not binding. Ravelli reserves the right to make any modifications for the purpose of improving the performances of the product.

Height	542mm
Width	610mm
Depth	590mm
Weight	105kg
Diameter of smoke exhaust	80mm
Min - Max calorific power	3.7Kw/h - 6.6Kw/h
Min - max hourly consumption of pellets	0.8kg/h - 1.6kg/h
Electrical power absorbed during operation	240W
Supply	220V - 50Hz
Hopper Capacity	15kg
Space Heating Efficiency	82%

2. Positioning and Installation of the wood pellet fire

2.1 Positioning

Generally the Sara should be installed in a centrally located position within the home. When deciding where to position the appliance, you must consider the following:

1. The place of installation of the pellet fire must comply with local and national regulations. The pellet fire must be fuelled only with quality pellets manufactured to standard AS/NZS 4014.6. The pellet fire cannot operate using traditional fire wood.
2. Do not install a pellet fire in a bedroom or room where people sleep.
3. Sara has a convection fan which blows air through tubes in the direction the fire faces. For optimum performance and heat circulation, locate the pellet fire in a large and open room that is centrally located in the house.
4. The fire requires a 230 volt power supply and comes with a 2m plug in power lead. There must be easy access to the socket so the fire can be isolated from the power if required. If the cable supplied is not long enough to reach the nearest outlet, use a suitable 3 pin extension cord. A surge protector is recommended for use with all Ravelli pellet fires.

2.2 Installing

Installation of the Ravelli Sara Wood Pellet Fire must be undertaken by an approved installer, who must then give the purchaser a declaration of conformity of the appliance, and will assume all responsibility for the final installation and consequent correct function of the installed product.

Please read this Manual thoroughly before commencing installation, as failure to follow the instruction could cause damage to the pellet fire or property. It is also necessary for the registered installer to take into consideration all the laws and national, regional, provincial and local regulations present in the country in which the appliance has been installed. In the event of failure to respect these precautions, Pellet Fire Solutions declines all responsibility.

1. The fire must be installed on a floor with sufficient carrying capacity. If the existing building does not meet this requirement, appropriate measures must be taken (i.e. a load distribution plate).
2. Sara must be installed on a non-combustible surface. This surface must protrude a minimum of 150mm from the front of the closed pellet fire door and a minimum of 200mm from the side of the appliance. Please note that if a floating hearth is to be installed, an allowance must be made below the fire for installation of the chosen surround.
3. Check clearances to combustibles (see "5. Creating the Cavity" on page 26) to ensure sufficient space is created in the cavity, and that the position of structural elements near the proposed flue have adequate clearance.
4. Check clearance for service – as the Sara is designed to be pulled out, as long as there is front access, this should be sufficient.
5. Check there is sufficient ventilation for combustion air and this is unaffected by mechanical extraction. An external air intake may be required. (see "5. Creating the Cavity" on page 26 for cavity ventilation requirements).
6. There must be sufficient circulation of air in the room where the pellet fire is installed. Never open the door of the pellet fire while it is functioning.
7. Check there is a suitable flue location (studs, joists, rafters etc).
8. Sara has been Safety Tested to AS/NZS 2918:2001 using the Davins manufactured flue, Test Report ARS 05/1185. Installation is not exclusive to these nominated kits, though an alternative flue should only be considered following consultation with your local council.
9. Because of the positive pressure in the flue, sealing of all 75mm stainless joints is mandatory - use high temperature Maniseal. Both inner and outer flue joints must be riveted using stainless steel rivets.

10. Before connecting the pellet fire electrically, the connection of the exhaust spigot must be completed (specifically for non-aluminium pellet fires) with the flue. (All flue joins must be sealed with Maniseal exhaust cement).
11. Seismic Restraint - please see "9. Seismic Restraint" on page 30 to see what is required.

12. Warranty - To validate the warranty following installation, a copy of the completed Warranty/ Producer's Statement must be forwarded to Pellet Fire Solutions - info@pelletfiresolutions.co.nz

ATTENTION

There are two critical components when installing a Sara Insert Wood Pellet re:

1) Ensure the wall cavity is the necessary size.

2) Ensure relevant clearances to combustibles are adhered to both inside and outside the cavity.

Depending on the circumstances, you may also have to consider the use of a hearth, and the installation of a support frame.

3. Safety Warnings and Maintenance Recommendations

DO NOT use this appliance as an incinerator.

3.1 Pellet Quality

Pellet quality is important - please read the following:

This wood pellet fire has been designed to burn ¼" (6mm) diameter wood pellets, manufactured to the AS/NZS 4014.6 standard only.

The performance of this wood pellet fire is greatly affected by the type and quality of wood pellets being burned. As the heat output of various quality wood pellets differs, so will the performance and heat output of the wood pellet fire.

Caution: It is important to select and use only pellets that are dry and free of dirt or any impurities such as high salt content. Wood pellets manufactured to the AS/NZS 4014.6 standard are recommended. Dirty fuel will adversely affect the operation and performance of the unit and will void the warranty. The Pellet Fuel Industries (PFI) has established standards for wood pellet manufacturers. We recommend the use of pellets that meet or exceed these standards. Ask your dealer for a recommended pellet type.

1. The protection grill inside the pellet tank must never be removed.

2. Do not light the heater without having first performed the daily inspection, as described in the Sara Owner's Manual. Scrupulously follow the maintenance program.
3. Do not switch off the pellet fire by disconnecting the electricity mains supply.
4. Do not clean the pellet fire until the appliance and the ashes have cooled down completely.
5. Carry out all operations in maximum safety.
6. When the pellet fire is operating, the surfaces, glass, handle and pipes become very hot. During operation these parts must only be touched using adequate heat protection.

3.2 Spare Parts

Use original spare parts only. Do not wait for the components to be worn out before replacing them. Replace any worn component before it is completely broken, to prevent any accidents caused by the sudden breakage of components. Perform periodic maintenance checks as described in "2. Positioning and Installation of the wood pellet fire" on page 23.

3.3 Responsibility

Ravelli and Pellet Fire Solutions declines all responsibility, both civil and criminal, with the delivery of this manual, for any accidents deriving from partial or total failure to observe the instructions it contains.

Ravelli and Pellet Fire Solutions declines all responsibility deriving from the improper use of the pellet fire, from its incorrect use by the user, by unauthorised modifications and/or repairs or from the use of spare parts which are not original.

Ravelli and Pellet Fire Solutions declines all direct civil or criminal responsibility due to:

- Poor maintenance.
- Failure to observe the instructions in the manual.
- Use not compliant with the safety instructions.
- Installation that is not compliant with the manual and regulations in force in the country.
- Installation by personnel who are not qualified or authorised.

- Modifications and repairs that are not authorized by the manufacturer.
- Use of spare parts that are not original.
- Exceptional events.

If you require further information, please contact your Pellet Fire Solutions pellet fire dealer.

In accordance with the requirements of AS/NZS 2918:2001 Sara must be secured by seismic restraint.

3.4 Flammable Liquids

Never use gasoline, gasoline-type lantern fuel, kerosene, charcoal lighter fluid or similar liquids to start or 'freshen-up' a fire in the heater. Keep all such liquids well away from the heater while it is in use.

4. Dimensions - Sara Insert Pellet Fire

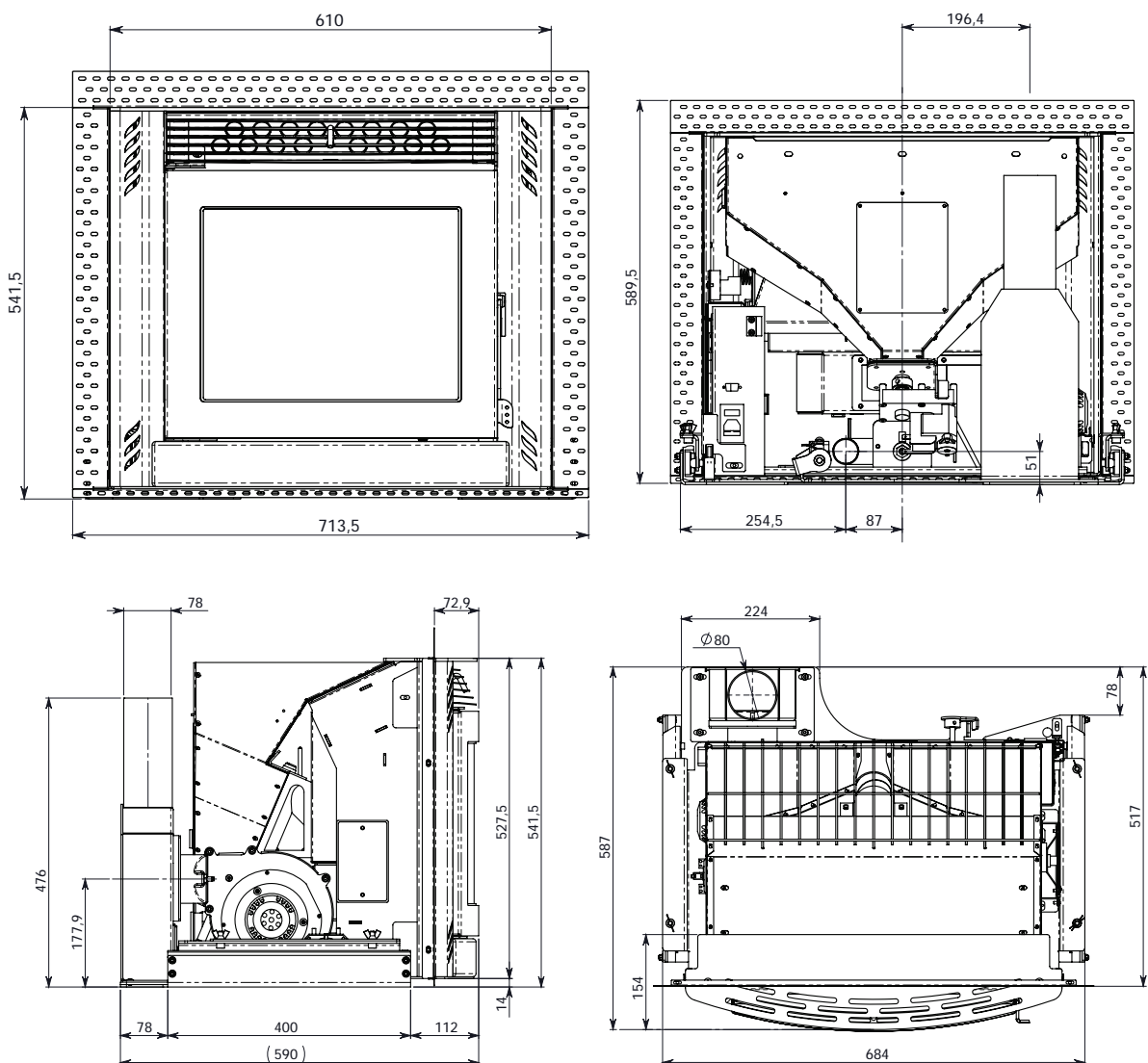

Refer to Safety Test 08/1861R1 for all clearances to combustible.

5. Creating the Cavity

As the Sara Insert Wood Pellet Fire is typically installed in new homes, it is necessary to build a compliant cavity that will house the fire and the frame. The front fascia of the enclosure must be made of a fireproof rated board (above 80°C) such as (but not limited to) Micore, Supalux or Eterpan, and this must extend to a minimum of 330mm above the top of the fire. Within the cavity, there must be a minimum of 300mm clearance to combustibles above the fire, and a minimum 600mm gap between the top of the fire and the ceiling of the cavity. The cavity also requires a minimum of 100cm² ventilation.

Internal Cavity Dimensions

(A) Width:	1030mm (min)
(B) Depth:	590mm (min)*
(C) Height:	2090 - 2320 mm**

* Includes 100mm clearance from rear of flue spigot box. Also allowing for 100mm thick wall.

** Dependent on height at which the support frame is set.

Wall Opening

(D) Width:	720mm
(E) Height:	550mm

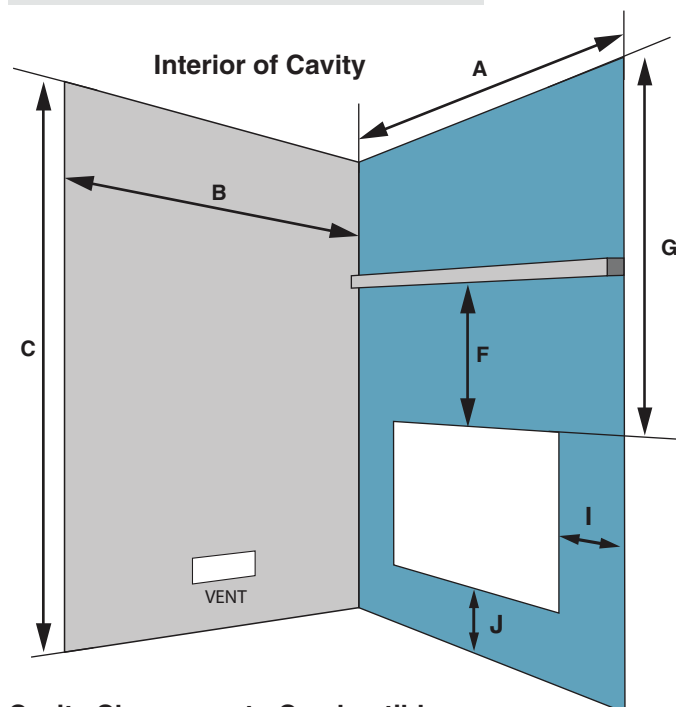

Cavity Clearances to Combustibles

(F): from top of fire	300mm
(G): from top of fire to cavity ceiling	600mm
(H): from top of opening to combustibles mantle	330mm (min)
(I): from side of opening	210mm (min)
(J): from bottom of opening	300 - 530mm, depending on height of support stand.

Additional Clearances to Combustibles

(K): from exhaust spigot to cavity wall	100mm
(L): from side of fire to cavity wall	210mm
(M): hearth depth from front of glass	150mm
(N): hearth width	1030mm

Exterior of Cavity

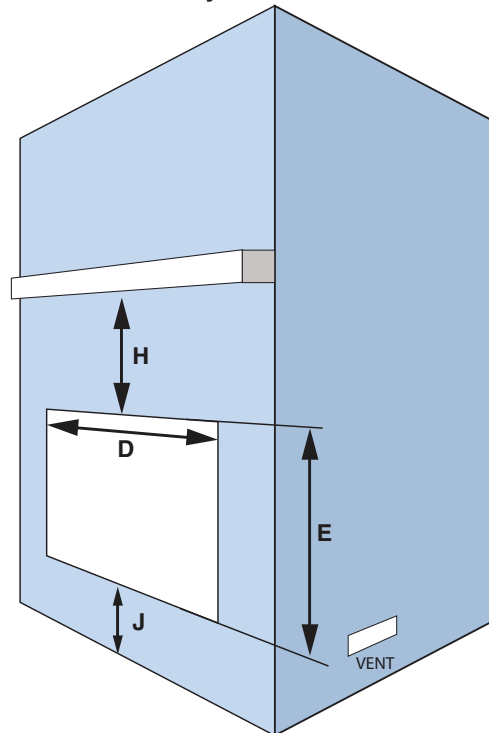

Surround Dimensions

Small Black (Flush)	692mm (w) x 609mm (h)
Stainless Steel	914mm (w) x 830mm (h)

Built-in fire clearances don't apply in a non-combustible cavity. The above clearance to combustibles on the flue are only applicable within the fire envelope. Clearance outside this, eg at a ceiling/wall thimble reverts to 25mm as per ARS flue test 05/1185.

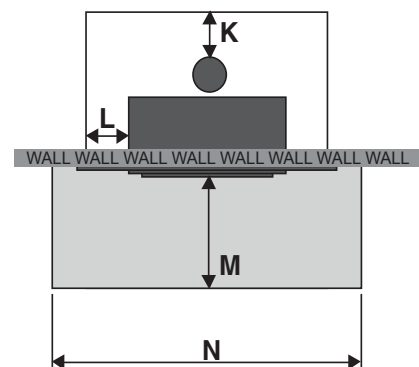

If installing a floating hearth, ensure sufficient clearance is left below the fire to allow for installation of the chosen surround.

6. Installing into an existing cavity - New Build or Masonry

As the Sara Insert Wood Pellet Fire is typically installed into a masonry cavity, it can still be installed into a compliant cavity that will house the fire and the frame. The front fascia of the enclosure must be made of a fireproof rated board (above 80°C) such as (but not limited to) Micore, Supalux or Eterpan, and this must

extend to a minimum of 330mm above the top of the fire. Within the cavity, there must be a minimum of 300mm clearance to combustibles above the fire, and a minimum 600mm gap between the top of the fire and the ceiling of the cavity. The cavity also requires a minimum of 100cm² ventilation.

Internal Cavity Dimensions (to combustibles)

(A) Width:	1030mm (min)
(B) Depth:	590mm (min)* (Masonry - 490mm)

* Includes 100mm clearance from rear of flue spigot box, and allows for a 100mm wall thickness. If this measurement is less than 500mm, a custom surround will be required. Ensure that extra depth required at 'B' is also added to the hearth measurement "K".

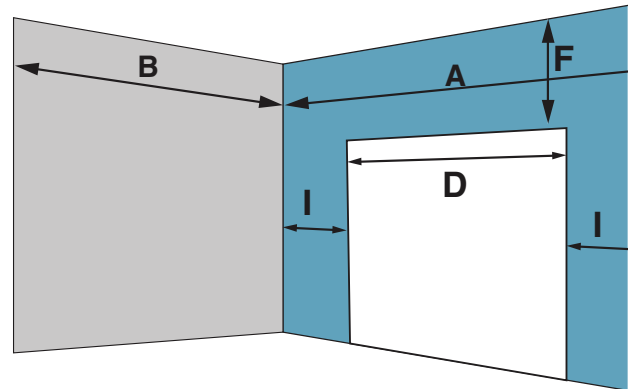

Wall Opening

(D) Width:	720 - 875mm	(Masonry - 720mm)
(E) Height:	600mm	(Masonry - 600mm)

Cavity Clearances to Combustibles

(F): from top of opening (inside)	300mm (min)
(G): from side of opening	210mm (min)
(H): from top of opening (outside)	330mm (min)

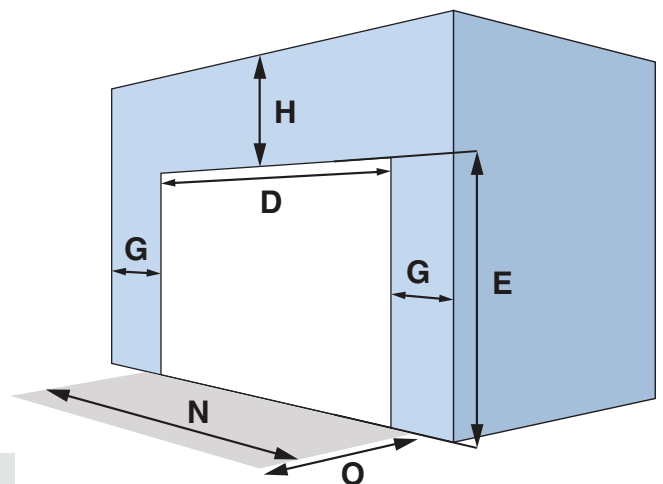

Additional Clearances to Combustibles

(K): from exhaust spigot to cavity wall	100mm
(L): from side of fire to cavity wall	210mm
(M): hearth depth from front of glass	150mm
(N): hearth width	1010mm
(O): hearth depth from wall	290mm

Built-in fire clearances don't apply in a non-combustible cavity. The above clearance to combustibles on the flue are only applicable within the fire envelope. Clearance outside this, eg at a ceiling/wall thimble reverts to 25mm as per ARS flue test 05/1185.

If installing a floating hearth, ensure sufficient clearance is left below the fire to allow for installation of the chosen surround.

Surround Dimensions

Retro Surround	895mm (w) x 665mm (h) x 62mm (d)
-----------------------	----------------------------------

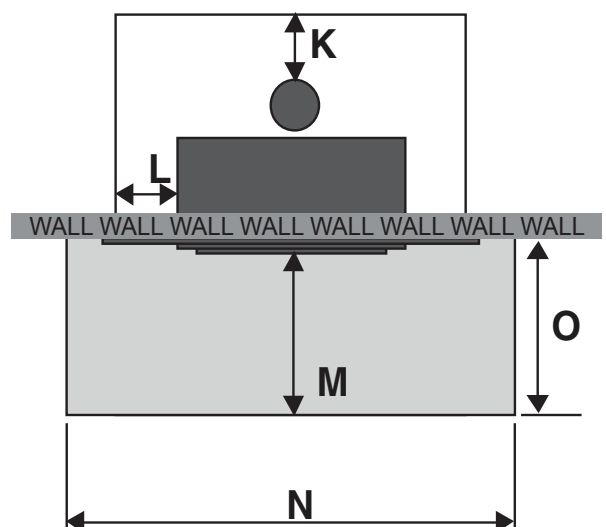

7. Architectural Drawings

7.1 Example of Cavity Design - Section View

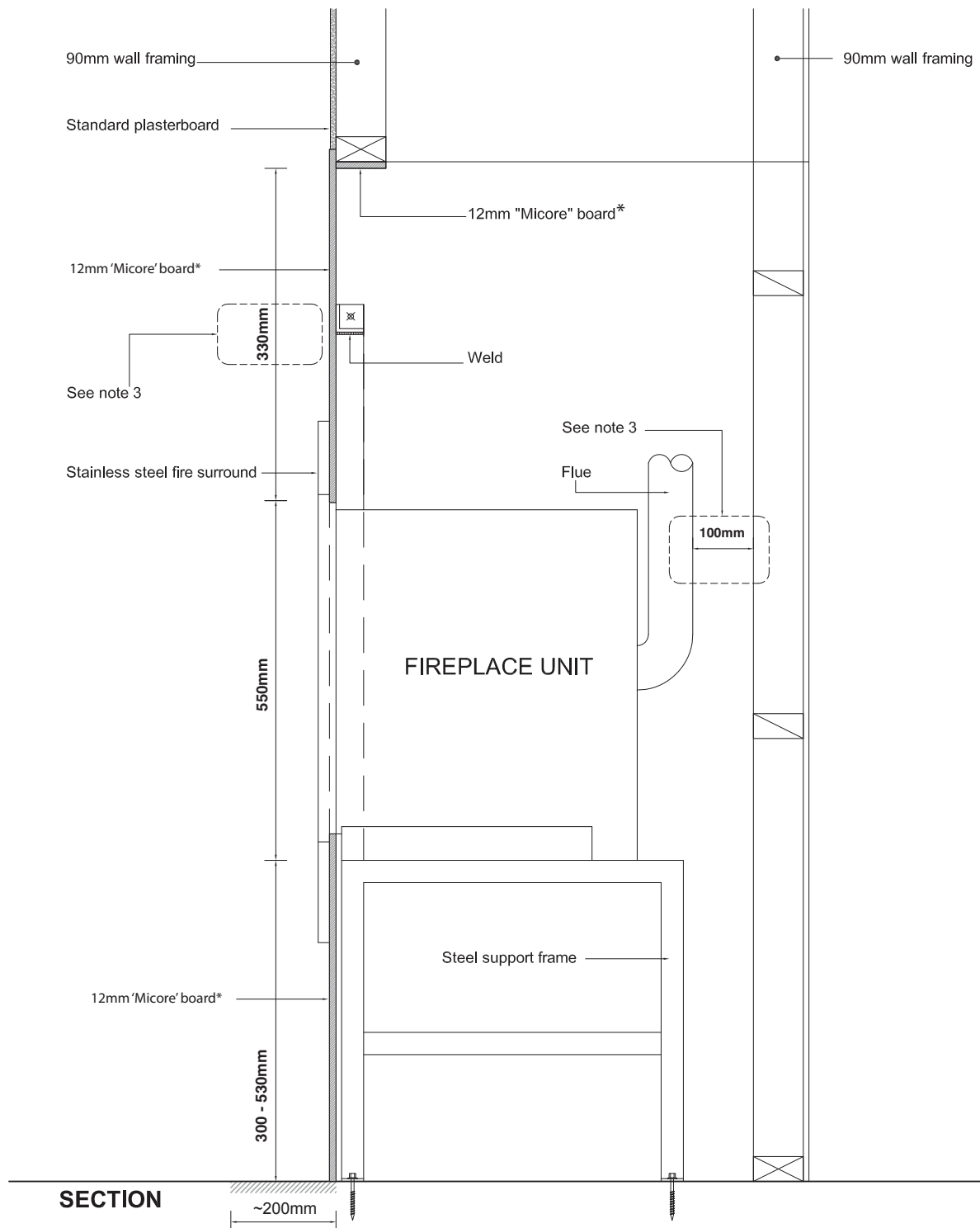

NOTES

1. Angle section for support fixed to timber frame/floor using coach screws or 'Dynabolts' when fixing to concrete.
2. The joint for fire rated board* and Plasterboard located over frame member must be stopped to manufacturer's instructions. Note: Wallpaper is not permitted on the front of the enclosure.
3. Comply with all minimum distance to all combustible surfaces. Any modifications to the dimensions shown to be verified by consultation with the relevant Building Consent Authority.
4. Ensure there is a minimum of 100cm² ventilation into the cavity (this does not need to be from the outside).
5. Installers must ensure adequate vermin proof measures are incorporated into the cavity construction (if applicable).

*Ensure product being used is fireproof rated above 80°C eg Micore, Supalux, Eterpan or similar

7.2 Example of Cavity Design - Top View

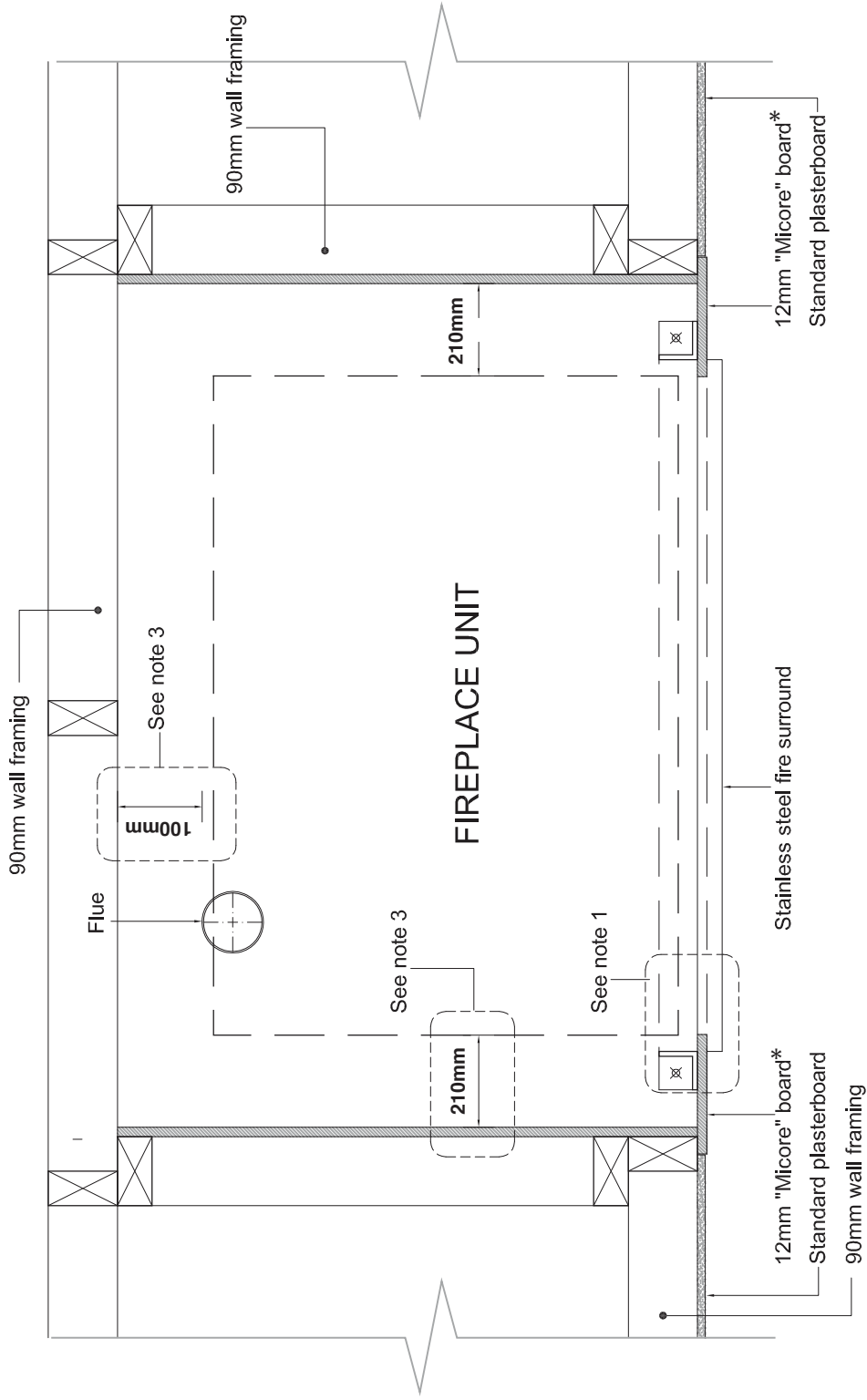

NOTES

1. Angle section for support fixed to timber frame/floor using coach screws or 'Dynabolts' when fixing to concrete.
2. The joint for fire rated board* and Plasterboard located over frame member must be stopped to manufacturer's instructions. Note: Wallpaper is not permitted on the front of the enclosure.
3. Comply with all minimum distance to all combustible surfaces. Any modifications to the dimensions shown to be verified by consultation with the relevant Building Consent Authority.
4. Ensure there is a minimum of 100cm² ventilation into the cavity (this does not need to be from the outside).
5. Installers must ensure adequate vermin proof measures are incorporated into the cavity construction (if applicable).

*Ensure product being used is fireproof rated above 80°C eg Micore, Supalux, Eterpan or similar

8. Adjusting the Support Frame

The Sara Wood Pellet Fire must be installed on the supplied, adjustable support frame. The height of this frame can be set at the home-owner's desired height, up to a maximum of 530mm.

The frame is adjusted by manipulating the bolts, which are located on each of the four legs to achieve the desired height.

9. Seismic Restraint

All installation scenarios for Sara require the use of hold-down anchors (one at each corner).

10. Fixing to Concrete Floor

- Minimum M8 expansion anchors (M10 recommended) or min M8 epoxy-set anchors.
- Approved Anchors: Expansion Anchors-Ramset Dynabolt and Trubolt, Hilti HAS.
- Epoxy-set Anchors – Ramset Epcon, Ramset Chemset and Hilti HVU.

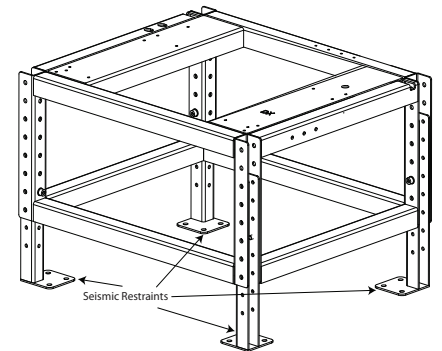
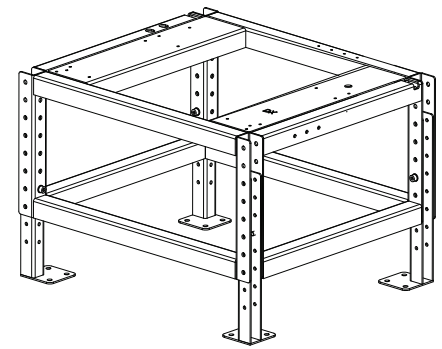

Seismic Restraint Locations

11. Fixing to Timber Flooring only

Minimum 14g x 60 screws (6.3mm diameter) or M10 X 90 coach-screws. Thickness of flooring must be 20mm minimum. The flooring shall be fixed to the nearest joist with two 8g x 40 screws per hold down anchor.

12. Fixing to Timber Floor Framing

Minimum 14g x 60 screws (6.3 diameter) or M10 x 90 coach-screws. These shall be fixed a minimum of 40mm into the centre-line of the existing floor joists. If screws cannot be installed directly into an existing floor joist, slid blocking between joists (min size 90x45) shall be provided.

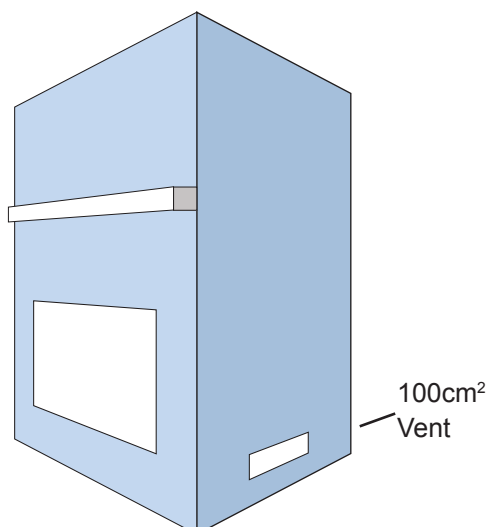

13. Ventilation

The Sara wood pellet fire requires fresh air to function properly. Without sufficient ventilation, the combustion process can be compromised, resulting in issues such as a lazy flame, smoke, incomplete fuel combustion, wasted fuel, excessive ash build-up and clinker.

To ensure the wood pellet fire does not struggle to access combustion air, ventilation (air vents) should be situated as close to the fire as practicable, within the parameters of the cavity.

14. Television Clearances

If electrical equipment (eg Plasma TV, LCD TV or home theatre) is to be installed above the wood pellet fire, we recommend installing a non combustible mantle below the TV screen, or recessing the TV screen into the wall, for heat protection.

The clearances shown are recommended minimums, and are to be treated as suggestions only.

The end user is responsible for checking the installation instructions and clearance requirements of their electrical appliances to ensure the appliance is suitably located in relation to the wood pellet fire. Pellet Fire Solutions and Ravelli does not guarantee that these recommended clearances will be appropriate for all electrical equipment

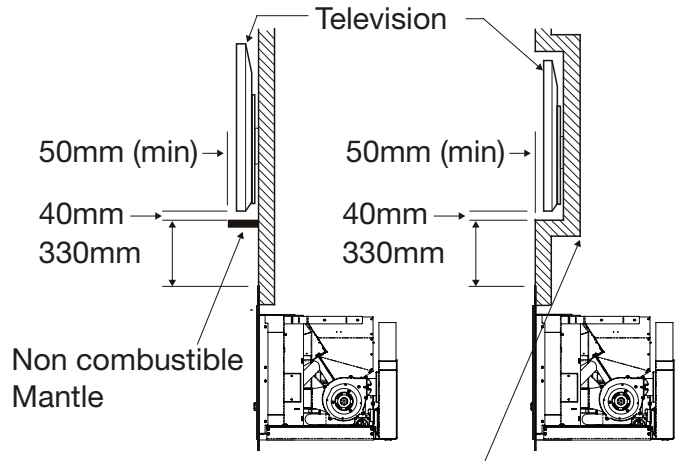

To be zero rated using eterpan etc with a 12mm air gap to comply with AS/NZS 2918 : 2001

15. Flashing Options

Decktite - For all Steel Roof Profiles



TILEFLASH for Concrete, Clay Tile and Slate Roofs

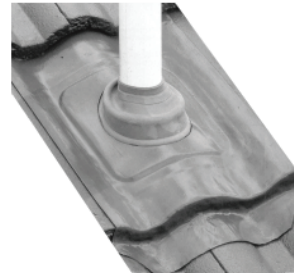

Please circle the flashing option to be used. When considering an alternative method please consult your local council.

16. Flueing

55 Ravelli Sara & Camino - new home (non-Chimney installation)

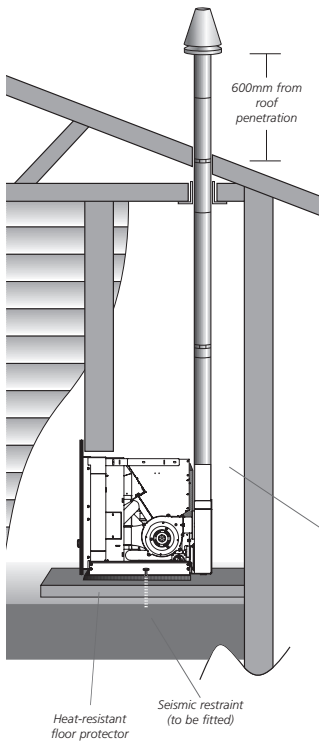

This flue kit may be used in new or existing timber chimneys. The overall height of the flue is 3.6m. Kit is supplied in a carton.

Each 55 Built-in-Heater Flue Kit (non-Chimney installation) contains:-

Part No	Description	Quantity
1	Galvanised outer liner ø100mm x 900mm long	4
2	Stainless steel inner liner ø75mm x 900mm long	4
5	Inner/outer flue liner spacer	2
6c	Ceiling thimble ø107mm hole	1
46	Velocity cone	1
9	Rain cap 100mm	1
702	Support angle 950mm long - 40mm x 40mm sides	2

25mm minimum clearance if lined:
75mm minimum clearance if unlined

Note: The Davin 55 Built-in-Heater Flue Kit for Sara and Camino (non-Chimney) complies with AS/NZS2918:2001 as per Applied Research Test Report 05/1185, dated 15 September 2005. All fires must be installed by a qualified installer as per the manufacturer's instructions and AS/NZS2918:2001.

55:1 Ravelli Sara & Camino - new home (Chimney installation)

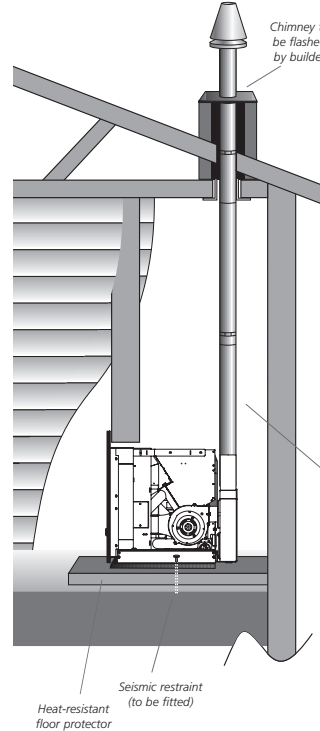

This flue kit may be used in new or existing timber chimneys. The overall height of the flue is 3.6m. Kit is supplied in a carton.

Each 55:1 Built-in-Heater Flue Kit (Chimney installation) contains:-

Part No	Description	Quantity
1	Galvanised outer liner ø100mm x 900mm long	4
2	Stainless steel inner liner ø75mm x 900mm long	4
5	Inner/outer flue liner spacer	2
6	Ceiling Thimble ø107mm hole	1
46	Velocity cone	1
9	Rain cap 100mm	1
10	Telescopic offset 75mm (Stainless) - (2 x 45° bends)	1
11	Telescopic offset 100mm (Galvanised) - (2 x 45° bends)	1
702	Support angle 950mm long - 40mm x 40mm sides	2

25mm minimum clearance if lined:
75mm minimum clearance if unlined

Note: The Davin 55:1 Built-in-Heater Flue Kit for Sara and Camino (chimney) complies with AS/NZS 2918:2001 as per Applied Research Test Report 05/1185, dated 15 September 2005. All fires must be installed by a qualified installer as per the manufacturer's instructions and AS/NZS2918:2001.

56 Ravelli Sara Insert Flue Kit

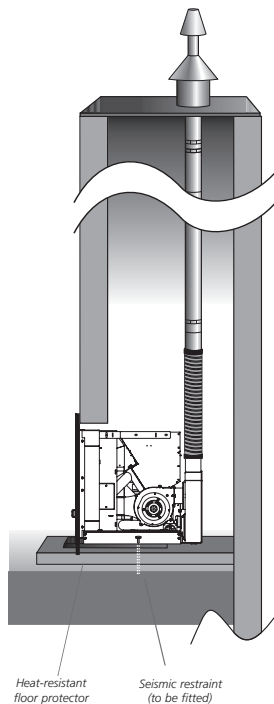

This flue kit may be used in replacement applications in masonry chimneys. The overall height of the flue is 6.0m. Kit is supplied in two cartons.

Each 56 Insert Flue Kit contains:-

Part No	Description	Quantity
2	Stainless steel inner liner ø75mm x 900mm long	5
4	Stainless steel inner ø75mm x 500mm long	1
46	Velocity cone	1
16	Clamp - flexible flue to stainless flue pipe	2
19	Flexible flue pipe - stainless steel ø75mm x 1m	1
74	Casing cover - standard ø75mm - ø300mm	1

Note: The Davin 56 Insert Flue Kit for Ravelli Sara complies with AS/NZS 2918:2001 as per Applied Research Test Report 05/1185, dated 15 September 2005. All fires must be installed by a qualified installer as per the manufacturer's instructions and AS/NZS2918:2001.

17. Controls and Menus



17.1 Description of Controls

- **P1** : Button to decrease general values
- **P2** : Button to increase general values
- **P3** : Turns fire on-off
- **P4** : Button to Change Ambient Temperature
- **P5** : Button to Change Operating Power
- **P6** : Multifunction Button
- **P7** : Multifunction Button

17.2 Turning the Unit On

1. Ensure burn pot is clean and free of ash
2. Slide the heat exchange cleaner in and out three times
3. To turn unit on hold down button '3' (ON/OFF)
4. Control Screen will show START
5. To change the Power setting, first press P5 then use buttons P1 or P2 to adjust the heat output of the fire.
6. To change the Thermostat Setting, first press P4 then use buttons P1 or P2 to adjust the thermostat setting
7. To turn unit off hold down button '3' (ON/OFF)
8. Control Screen will show FINAL CLEANING.

17.3 Menu Descriptions

The fire has various functions arranged in different menus. Some of these menus are accessible by the user, others are protected by a password and accessible only by a qualified technician.

All operations assume the fire is in the default OFF mode - press button (3) to achieve this. Some operations can also be performed in final cleaning – use caution if the fire has been running. If the fire should come with the wrong language set see “17.3.2 Menu Three - Select Language (Setting the Language)” on page 34.

Press button (7) for 3-4 seconds to access the menus, then use buttons (1) and (2) to scroll through the options, and button (7) to Enter/Select.

The menus are as follows:

- Menu 01 Set Clock
- Menu 02 Set Crono (Programmable Thermostat)
- Menu 03 Select Language
- Menu 04 View Settings
- Menu 05 State Stove (Fire Status)
- Menu 06 Hours Work
- Menu 07 Bank Data (protected by a password)
- Menu 08 Reset Hours (protected by a password)
- Menu 09 Default Settings (protected by a password)
- Menu 10 Select Recipe (protected by a password)

17.3.1 Setting the Clock

To set the clock, proceed as follows:

1. Remove and reset the electric supply of the stove using the general switch on the back.
2. The display will show FINAL CLEANING and then OFF.
3. Press button [7]. (Menu 01 Set Clock will appear)
4. Press [7] to enter into this menu. DAY CLOCK will appear:

- Set the desired day by using [1] or [2] according to the table shown below.

Display	Meaning
01	Monday
02	Tuesday
03	Wednesday
04	Thursday
05	Friday
06	Saturday
07	Sunday
OFF	Deactivated

- Press [7] to confirm
- TIME CLOCK will appear on the display and the current time will be shown. Change the hours of the day with [1] or [2] (24 hour clock) example: 4:30p.m would be 16:30
- Press [7] to confirm
- MINUTES CLOCK will appear on the display. Change the minutes of the day with buttons [1] or [2]
- Press [7] to confirm
- Press [3] to exit the menu

17.3.2 Menu Three - Select Language (Setting the Language)

Some fires may be in their default Italian language, if so proceed with Instruction Set 'A'.

If not, please use Instruction Set 'B'.

A. Setting fire from Italian language to your desired language. (English, German, French, Danish)

- Press button (7) - Menu 01 "Set Orologio" will appear.
- Press button (1) twice until you see - Menu 03 "Scegli Lingua".
- Press (7) to enter into this menu - "Italiano Lingua" should appear.
- Press (1) or (2) until you see "English Lingua" or select your desired language.
- Press (3) twice to return to the main screen.

B. Setting fire from English language to your desired language. (Italian, German, French, Danish)

- Press button (7) (Menu 01 "Set Clock" will appear)
- Press button (1) twice until you see (Menu 03 "Select Language")
- Press (7) to enter this menu ("English Lingua" will appear)
- Press (1) or (2) to change to your desired language.

- Press (3) twice to return to the main screen.

17.3.3 Menu Four - View Settings

In this menu you can check the values of the parameters set in the control unit. This menu is used when a Service Technician has to understand the parameters set in the machine, to find any modifications to improve the functioning of the stove.

17.3.4 Menu Five - Stove State (Fire Status)

In this menu, you can check the correct functioning of some of the key components of the pellet fire.



To enter this menu either

- Press Button (7) (Menu 01 "Set Clock" will appear)
- Then press and hold (6) for 3 seconds

Or

- Press (7) CLOCK SETTING MENU will appear
- Press (1) four times "fire State" menu, enter using (7).

This menu is for use by a service technician for commissioning and diagnostics, and for the customer when loading pellets into the auger when the fire has been completely run out of fuel.

17.3.5 Menu Six - Working Hours

The WORKING HOURS Menu shows the total run hours done by the fire.

To enter this menu, proceed as follows:

- Press Buttons (7) (Menu 01 "Set Clock" will appear).
- Press button (1) twice until you see (Menu 06 "WORKING HOURS MENU).
- Press (7) to enter this menu .
- Press (3) to return to the main screen.

17.3.6 Loading the Screw (Auger)

Insert Models - Loading the Auger should only be carried out in OFF mode



When the stove is new or the fire has run out of fuel, the auger will be empty. In this case it may be necessary to 'load' the auger so the fire will start.

To load the screw/auger, proceed as follows:

1. Press Button (7) (Menu 01 "Set Clock" will appear), then press and hold (6) for 3 seconds. The display will show "SCREW STATE".
2. Use Button (1) to turn the Auger On "SCREW 1" and button (2) to turn it OFF.
3. Once started auger will run for a couple of minutes
4. Remember to turn the screw OFF (SCREW 0) with button (2) before exiting, button (3)
5. Empty the burner pot of any pellets before starting the fire

Also see "17.3.4 Menu Five - Stove State (Fire Status)" on page 34.

17.3.7 How to synchronise the remote control with the fire

All insert stoves are fitted with remote-control, radio-wave handset and a receiver, located on the right-hand side of the stove. Sometimes, due to interference from other electrical household appliances (microwave ovens, satellite decoders, mobile phones) the connection between the stove and the handset may be interrupted. If this happens, the following operations must be carried out to reinstate the connection:

1. Switch the power to the fire off at the mains switch.
2. Press the triangle keys (1) and (2) on the remote together for about three seconds. The display will show "SCEGLI UNITA 0"
3. Using triangle key (2), select the unit frequency to be loaded (select unit 0 , 1 , 2 , 3) Note: 0 or 1

are usually the best but different houses may work better on other settings.

4. Switch the power to the stove back on (if the unit is pulled out this will need pushing back into its cradle) .
5. Press the red button (3).
6. If the operation is successful, UNIT LOADED 0, 1, 2 or 3 will appear on the remote. You may now need to turn the power to the stove off and back on again to refresh the connection with the remote.

18. Programming & Commissioning

This section refers to Password Protected sections of the Pellet Fire Menues. Only Pellet Fire Solutions approved pellet fire installers and technicians will have access to these passwords. If you are not a Pellet Fire Solutions approved installer or technician, please do not attempt to install, program or commission any pellet fire from Pellet Fire Solutions.

18.1 Sara Parameters - version BOX 03

Name	Program	Unit	Value	Before Programming	After Programming	Adjusted Settings
Minutes time out	PR01	Min	18			
Minutes start	PR02	Min	5			
Clean frequency	PR03	Min	60			
Cleaning duration	PR04	Sec	20			
Screw start	PR05	Sec	1.8			
Screw power 1	PR06	Sec	1.6			
Screw power 2	PR07	Sec	2			
Screw power 3	PR08	Sec	2.4			
Screw power 4	PR09	Sec	2.8			
Screw power 5	PR10	Sec	3.2			
Re-start threshold	PR11	°C	80			
No pellet threshold	PR12	°C	50			
Off threshold	PR13	°C	45			
Maximum threshold	PR14	°C	250			
Fan threshold	PR15	°C	80			
Smoke ignition	PR16	RPM	2100			
Ignition smoke speed	PR17	RPM	1950			
1 smoke speed	PR18	RPM	1500			
2 smoke speed	PR19	RPM	1720			
3 smoke speed	PR20	RPM	1930			
4 smoke speed	PR21	RPM	2140			
5 smoke speed	PR22	RPM	2350			
Air 1 speed	PR23	V	110			
Air 2 speed	PR24	V	120			
Air 3 speed	PR25	V	130			
Air 4 speed	PR26	V	150			
Air 5 speed	PR27	V	175			
Enable glow plug	PR28	on / off	ON			
Suct smoke cleaning	PR29	RPM	2800			
Screw cleaning	PR30	Sec	1.3			
Pre-heat glow plug	PR31	Sec	150			
Screw max load	PR32	Min	4			
Flame delta	PR33	°C	20			
Screw ignition	PR34	Sec	2.5			
Alarms delay	PR35	Sec	60			
xHZ frequency	PR36	Hz	50			

Degrees	PR37	°C / °F	°C			
Blackout	PR38	Sec	10			
Re-ignition block	PR39	Min	4			
T-extinction min	PR40	Min	5			
Fan 2 threshold	PR41	°C	-			
Comfort climate	PR42	on / off	OFF			
Fan 2 speed - 1	PR43	V	-			
Fan 2 speed - 2	PR44	V	-			
Fan 2 speed - 3	PR45	V	-			
Fan 2 speed - 4	PR46	V	-			
Fan 2 speed - 5	PR47	V	-			
Draft setting	PR48	on / off	OFF			
or for version Air 03						
Screw encoder	PR49	on / off	OFF			
Magnehelic on high	-	WG	- 0.11			

Comments

Please keep this parameter sheet for future reference

19. Technical Drawings

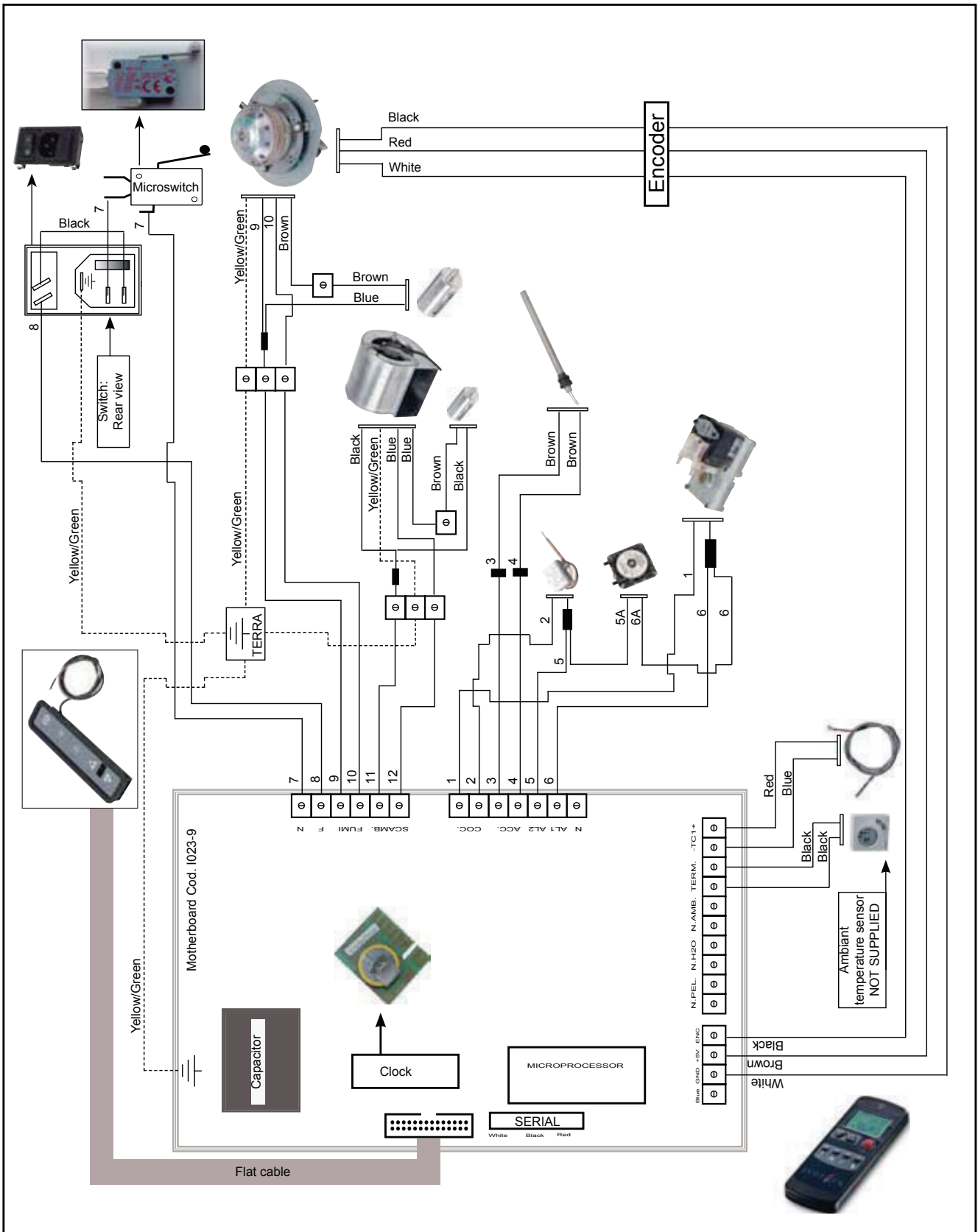



PRODUCER REGISTRATION FORM

This form must be completed and returned for every installation to qualify for warranty.

Post to: P O Box 11-245, Sockburn, Christchurch

Email to: info@pelletfiresolutions.co.nz

Customer Details:

Customer Name: _____

Postal Address: _____

Installation Address: _____

Phone Number	Cell Phone	Email Address
_____	_____	_____

Declaration by Owner: I hereby certify the above particulars are true and correct. My Pellet Fire Technician has demonstrated to me the correct operation of my Pellet Fire.

I understand that warranty conditions require an authorised Pellet Fire Solutions Installer to complete the installation

Signed: _____ Date: _____

Installation Details:

Pellet Fire Model & Serial Number: _____

Installation Date: _____

Freestanding Flue Kit: Internal External Standard

Fireplace Insert Flue Kit: Insert BIH

Installer Details: _____

Installers Name: _____ Phone Number: _____

Passed Inspection Yes/No (if no, why) _____

Declaration by Approved Technician: I _____ hereby certify that the above appliance has been installed and commissioned in compliance with Manufacturers Installation requirements and appropriate New Zealand Standards/Local Council requirements.

Signed: _____ Date: _____